



University of New Hampshire

Undergraduate Student
Handbook

Environmental Engineering

University of New Hampshire
Department of Civil and Environmental
Engineering

Academic Year
2019 – 2020



Table of Contents

Preface (Welcome).....	3
A. EnvE Program Philosophy	4
1. Program Description	4
2. Mission Statement.....	5
3. EnvE Program Educational Objectives and EnvE Program Outcomes	6
4. Grading Metric for EnvE Courses	7
5. EnvE Engineering Tools.....	8
B. EnvE Curriculum.....	9
1. Advising Worksheet.....	9
2. EnvE Course Descriptions	11
3. Required Courses	15
4. Program Policies and Requirements	16
5. Writing Requirements.....	16
6. Transfer Credits	16
7. Pass/Fail Regulations	18
8. Incomplete (IC) Grades.....	18
9. Exchange Programs	19
10. Professional Registration	20
11. Honors in Major.....	20
12. Five Year BS/M.Eng. Option.....	21
13. Accelerated Masters Program	21
14. Leave of Absence Policy	21
C. EnvE Faculty.....	23
1. Faculty Contact Information.....	23
2. Faculty Bios	24
D. EnvE Ethics.....	28
1. NSPE Code of Ethics	28
2. UNH Academic Honesty Policy	30
3. EnvE Student Code of Ethics.....	34
E. Facilities and Resources	35
1. Gregg Hall.....	35
2. Kingsbury Hall.....	36
3. Student Mailboxes	36
4. Textbooks.....	36
5. Tutoring.....	37
6. Academic Advising.....	37
7. Student Organizations.....	37
8. MyCourses by Canvas	40
9. Important UNH Resources and Services	40
10. Important UNH Phone Numbers and Web Addresses.....	43
F. Environmental Engineering Research Groups.....	44
1. Overview.....	44
2. Staff Directory	46

Welcome!

On behalf of the Environmental Engineering faculty and staff, welcome to the University of New Hampshire and the 2019-2020 academic year. You have taken the first step toward an exciting, rewarding and cutting edge career in environmental engineering.

Environmental engineers plan, design and construct public and private facilities to minimize the impact of human activity on the environment and to protect human health. They are strong contributors to society, and provide responsible social, economic and environmental benefits and enhance the quality of life around the world. Environmental engineers design and build drinking water treatment systems, municipal and industrial wastewater treatment plants, solid waste management facilities, contaminated groundwater remediation systems, and hazardous waste remediation facilities and provide solutions that are sustainable.

The environmental engineering (EnvE) accredited degree program's strong analytical core and multi-disciplinary focus, combining engineering and the sciences, prepares graduates for many opportunities in public, private, or academic sectors.

In this handbook, you will find useful and pertinent information regarding our programs, our facilities and resources, as well as our faculty and staff. To ensure that your experience at UNH is fulfilling, we encourage you to take advantage of the many opportunities available to you while you are here, such as student organizations, various competitions, and undergraduate research.

Our faculty members are renowned for excellence in teaching and research. We want you to succeed and be prepared to face the challenges of today and tomorrow. Please consult the handbook for information through your undergraduate career, meet with your faculty academic advisor or any of our faculty or staff, if you have any academic or non-academic questions, conflicts, problems or issues. We are here to help you! Welcome to the EnvE family. Go Wildcats!

Best wishes in the academic year ahead,

Nancy E. Kinner, Ph.D.
University Professor
Professor of Civil and Environmental Engineering
EnvE Undergraduate Coordinator

Paula Mouser, Ph.D., P.E.
Associate Professor of Civil and Environmental Engineering
EnvE Program Administrator

Erin Santini Bell, Ph.D., P.E.
Professor and Department Chair
Civil and Environmental Engineering

A. EnvE Program Philosophy

1. Program Description

Bachelor of Science in Environmental Engineering

Environmental engineers graduating with a B.S. EnvE degree will plan, design, and construct public and private facilities to minimize the impact of human activity on the environment and to protect human health. For example, environmental engineers design and build drinking water treatment systems, municipal and industrial wastewater treatment plants, solid waste management facilities, contaminated ground water remediation systems, and hazardous waste remediation facilities. These facilities must meet regulatory requirements, be cost effective to build and maintain, be safe to operate, and have minimal environmental impact. EnvE students can also focus on sustainable engineering with a required course (CEE 705) in junior year and two or three senior year electives, including design electives.

In CEE 420, students are introduced to the full spectrum of environmental engineering topics that they will subsequently explore in design teams during their degree program. As part of these experiences, students visit and tour field sites (CEE 520), and through junior and senior year classes and seminars (i.e., ASCE, EWRI, Civil and Environmental Department), they interact with engineers who talk about engineering consulting and design practices applied to local, national and international projects. As part of these projects, students: (i) analyze treatment alternatives; (ii) recommend a system that meets regulatory operational needs, and is sustainable; and (iii) prepare an implementation schedule and project budget. Detailed design projects are performed in CEE 731 and two design electives. CEE 797/798 serve as a capstone design experience where students work on a multi-disciplinary environmental engineering project and apply skills learned in other courses, while working with real-world clients. EnvE students do not have to take a course in the Discovery Biological Science category since they satisfy this category with CEE 724, Environmental Engineering Microbiology.

The University of New Hampshire Environmental Engineering Program is accredited by the Engineering Accreditation Commission of ABET, <http://www.abet.org>, 415 North Charles Street, Baltimore, MD 21201 – telephone: (410) 347-7700. ABET is an acronym for the Accreditation Board for Engineering and Technology, Inc. It is important that the engineering program from which you graduate is ABET-accredited because that is one of the requirements in the process of obtaining a Professional Engineering (PE) license. An ABET-accredited engineering program is defined by its educational objectives and outcomes and its curriculum. **Program Educational Objectives** describe the accomplishments a program's graduates are expected to attain within a few years of graduation. The educational objectives are unique to the program and determined by the faculty and stakeholders (e.g., the EnvE Advisory Board). **Student Outcomes** describe what students are expected to know and be able to do by the **time of graduation** (e.g., skills, knowledge, behaviors). The **Curriculum** outlines the academic path that students in the program take to meet the outcomes by the time of graduation and ultimately, the objectives they accomplish after graduation.

2. Mission Statement

The Environmental Engineering (EnvE) Program in the Department of Civil and Environmental Engineering at the University of New Hampshire offers an undergraduate degree in environmental engineering that prepares students for productive careers in the public and private sectors and graduate studies. The Program emphasizes fundamental principles in environmental engineering and design, built upon a strong base of chemistry, physics, mathematics and engineering science. The Program prepares its students to work in multi-disciplinary teams that analyze, formulate and communicate sustainable solutions to complex environmental problems. The importance of developing sustainable solutions that provide economic, social and environmental benefits to society is emphasized. The Program instills in its students an appreciation of the responsibilities of engineers to society and teaches them the skills necessary to continue learning and improving their professional expertise throughout their careers. The curricula prepare students to plan and design safe systems to minimize the impact of human activity on the environment and protect human health.

3. EnvE Program Educational Objectives and EnvE Student Outcomes.

MISSION OF THE DEPARTMENT OF CIVIL AND ENVIRONMENTAL ENGINEERING¹

- Pursue and disseminate knowledge through teaching, scholarship, outreach, and public service.
- Provide excellent undergraduate and graduate education.
- Advance the state-of-the-art in science and engineering by conducting research.
- Enhance the quality of life for people in New Hampshire and beyond.

BSENV PROGRAM EDUCATIONAL OBJECTIVES²

(What graduates are expected to attain five years after graduation.)

1. Professional employment, primarily in the civil and environmental engineering disciplines.
2. Commitment to continuous learning through graduate and post-graduate education, coursework, and research.
3. Being resourceful in finding solutions, and retaining ownership and accountability for their work.
4. Positions of leadership, directing the work of others.
5. Professional licensure or certification in civil and environmental engineering disciplines and other professions.
6. Positions and active participation in community, public, and professional service.

BSENV PROGRAM STUDENT OUTCOMES³

(What students are expected to know and be able to do by the time of graduation.)

1. To have obtained a working knowledge⁴ in environmental engineering areas of water and wastewater treatment, environmental health and safety, solid and hazardous waste management, sustainability, and water resources.
2. To be able to locate, assess, and compile data, to design and perform experiments to gather data, and analyze data to draw conclusions.
3. To have an ability to use and learn techniques, skills, or software necessary for engineering practice.
4. To be able to effectively contribute as a member of multi-disciplinary teams.
5. To be able to effectively communicate and support ideas in documents and presentations to a variety of audiences.
6. To be able to apply principles of mathematics, science, and engineering to identify, formulate, and solve problems.
7. To have been prepared for the Fundamentals of Engineering examination.
8. To have the broad education necessary to have an understanding of contemporary issues and the interaction between sustainable and ethical engineering practice and global, social, economic, political, and environmental issues.
9. To have a recognition of the need for leadership, and an ability to engage in life-long learning and to understand the importance of professional licensure.
10. Given realistic economic, environmental, social, political, and ethical constraints, to be able to critically analyze and design systems or processes to meet society's current needs without compromising the ability of future generations to meet theirs.

¹ Approved by the Faculty on 29 October 2013, updated and reaffirmed 24 February 2015, 12 December 2016, 20 May 2019.

² Approved by the Faculty on 2 March 2018, 20 May 2019.

³ Approved by the Faculty on 2 March 2018, 20 May 2019.

⁴ A "working knowledge" is defined as understanding and being able to apply a sub-discipline in analysis and design as demonstrated by successful completion of two or more courses with a substantial focus in that sub-discipline.

4. EnvE Grading Metric

ENVE PROGRAM: UNIVERSITY OF NEW HAMPSHIRE

REVIEWED BY ENVE FACULTY AUGUST 2016

Grade	UNH Standard	EnvE Standard	Level of <u>Competency</u>	Perception of Performance by an Experienced Engineer	Quality of Work	Need for Further Review and Instruction
A (4.0)	Excellent	Excellent	Mastery. Above level expected of a typical student or new hire at this level.	Experienced engineer would be impressed by quality of work, would be pleased by work output, and would see leadership potential.	Creative. Innovative. Student finds new ways to solve difficult problems. Few minor errors, if any, exist. No significant omissions. Work is clear, concise, readily checked, and can serve as a reference to others.	Student has mastered the subject and is capable of teaching others.
B (3.0)	Superior	Good	Competent. Level expected of a typical student or new hire.	Experienced engineer would be satisfied.	Occasional errors or minor omissions. On review, student can recognize problems and can correct them without supervision.	Student is capable and can review topics on his or her own where needed.
C (2.0)	Satisfactory, Competent	Fair	Minimal level of competence. Below level expected of an entry-level engineer for assignment of work in this area.	Experienced engineer would be concerned.	Some errors or omissions present. Student may not find problems independently, but can correct them with the aid of reference material.	Deficiencies exist. Student encouraged to study reference materials
D (1.0)	Marginal	Poor	Incompetent. Should not be assigned work in this area.	Experienced engineer would be disappointed.	Work riddled with errors or substantially incomplete. Student cannot find problems and may not be able to correct them without direct supervision and guidance.	Poor understanding of the subject. Student advised to repeat coursework.
F (0.0)	Failure	Failure	Incapable of producing useful work in this area.	Experienced engineer would be alarmed, would certainly reassign the employee, and might consider firing a new hire for performing at this level.	Work of little or no value. Student may not be able to correct problems even with direct supervision.	Little or no understanding. Student must repeat coursework in its entirety.

5. BSEnvE ABET Engineering Tools August 2016

Tool	Introductory Courses	Teaching Method	Application Courses
Spreadsheet (e.g., Excel)	CEE 420	HW Assignments	CEE 650, CEE 720, CEE 620, CEE 731, CEE 723, CEE 724, CEE 797/798, Hydraulics Elective, ESCI 654
Graphing (e.g. Excel)	CEE 420	HW Assignments	CEE 650, CEE 720, CEE 620, CEE 731, CEE 723, CEE 724, CEE 797/798, Hydraulics Elective, ESCI 654 (CEE 721 Lab Elective)
Life Cycle Analysis	CEE 705	HW Assignments	CEE 705
Word Processing (e.g., Word)	CEE 420	Papers	CEE 650, Hydraulics Elective, CEE 620, CEE 731, CEE 797/798, CHE 709, CEE 520
Presentation Graphics (e.g., PowerPoint)	CEE 420	Presentations	CEE 650, CEE 620, CEE 724, CEE 705
Computer-Aided Drawing (CAD)	Tech 564	Lecture/Lab	CEE 620, CEE 797/798
Project Scheduler (e.g., MS Project, Quest)	CEE 502	Lecture/Lab	CEE 620, CEE 797/798
Cost Estimating (e.g., R.S. Means Cost Works)	CEE 502	Lecture/Lab	CEE 620, CEE 797/798
Information Sources and Retrieval	CEE 420	Presentation	CEE 620, CEE 724, CEE 797/798, CEE 705
Modeling (e.g.,LCA, Minteq WaterPro)	CEE 705	Lecture/Lab/Projects/Homework Assignments	CEE 723, ESCI 654, CEE 731
GIS	GIS Elective	Lecture/Lab/Projects/Homework Assignments	
Statistics (e.g., JMP)	MATH 644	Statistics Course	CEE 731, ESCI 654

Student: _____

Continuous line = prerequisite, dashed line = pre- or corequisite, * = "writing-intensive" (see Advising Note 6), solid corner triangle = critical path

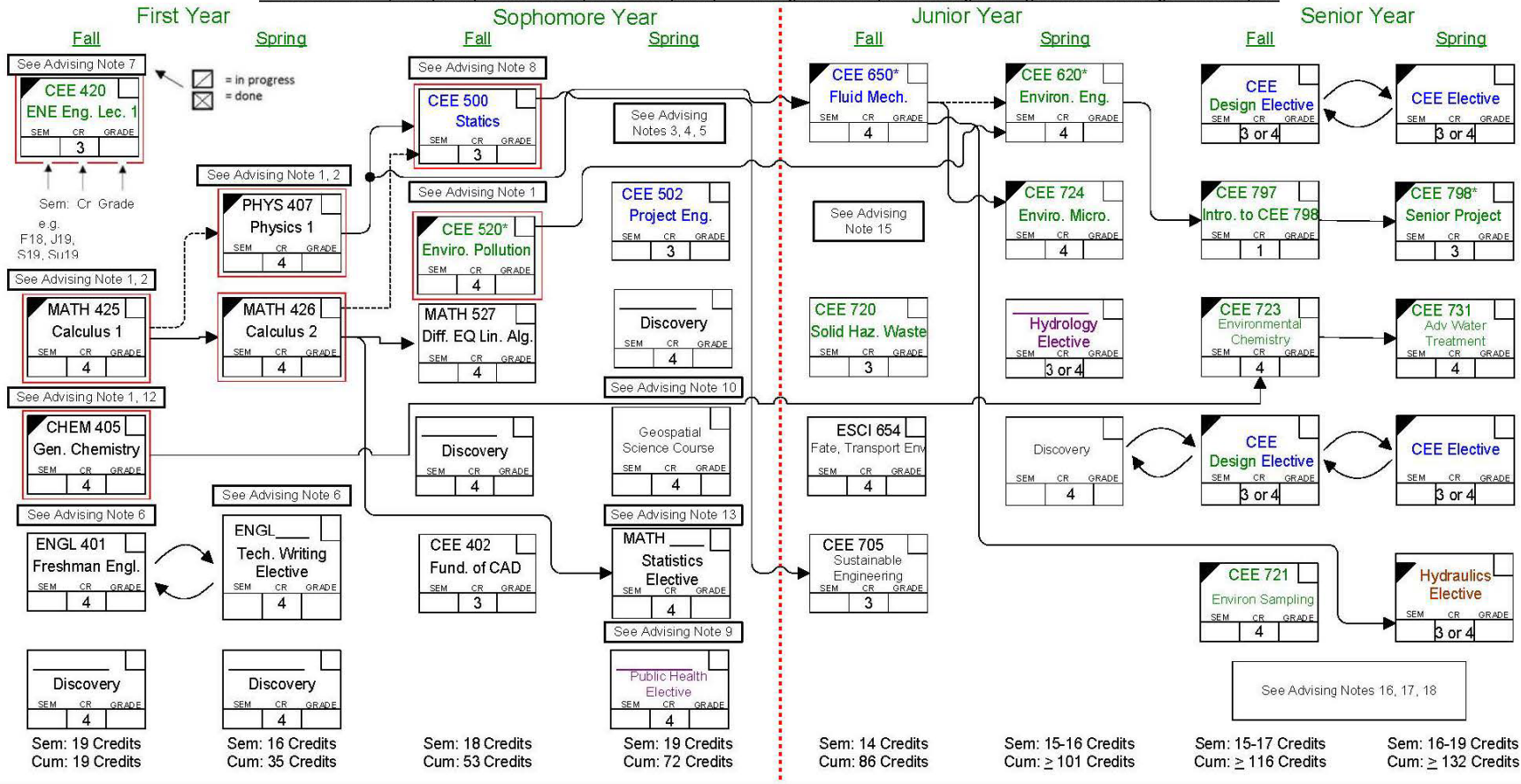

B. ENE MP Curriculum
1. Advising Worksheet

<p>Discovery in Disciplines</p> <p>FPA _____ <input type="checkbox"/></p> <p>HP _____ <input type="checkbox"/></p> <p>SS _____ <input type="checkbox"/></p> <p>Huma _____ <input type="checkbox"/></p> <p>WC _____ <input type="checkbox"/></p> <p>Inquiry Met (_____) <input type="checkbox"/></p> <p>Biological Science = CEE 724 Physical Science = PHYS 407 Enviro. Tech. in Soc. = CEE 520</p>	<p>Graduation Requirements</p> <p>1. ENE Major <input type="checkbox"/></p> <p>2. ≥ 132 Credits <input type="checkbox"/></p> <p>3. A minimum of 2 EnvE Design Electives <input type="checkbox"/></p> <p>4. University Discovery Courses <input type="checkbox"/></p> <p>5. University Writing Intensive Courses <input type="checkbox"/></p> <p>6. Overall GPA ≥ 2.00 <input type="checkbox"/></p> <p>7. GPA in Engineering Courses ≥ 2.00 <input type="checkbox"/></p>	<p>BSENE/Sustainability Dual Major*</p> <p><input type="checkbox"/> SUST 401 <input type="checkbox"/> 501 <input type="checkbox"/> 750</p> <p><input type="checkbox"/> NBS Elec: _____</p> <p><input type="checkbox"/> SSH Elec.: _____</p> <p><input type="checkbox"/> Elective 3: _____</p> <p><input type="checkbox"/> Elective 4: _____</p> <p><input type="checkbox"/> Elective 5: _____</p> <p>*No more than 8 cr may be used for both a minor and the major or for both majors in a dual major. Discovery electives are not considered "major requirements."</p>
--	--	--

ADVISING NOTES

Notes for Incoming Students and about Transfer Credit

- AP Courses:**
 - AP Calc*—AB=4/BC=3: MATH 425 optional. AB=5/BC=4: take MATH 426. BC=5: take MATH 527.
 - AP Chem*—3: get CHEM 403 credit, still need 404 or 405. 4 or 5: get CHEM 403 & 404, or 405 credit.
 - AP Physics*—3,4,5: get Physics 407 credit.
 - AP Environmental Science*—You receive credit for NR 435 but still need to take CEE 520.
- MATH 418 and 425*—if MATH 418 is taken Fall of first year, all MATH courses move back one semester. MATH 418 (4 credits) cannot be used toward cumulative credits (≥ 132) needed for graduation. If MATH 425 is taken 1st semester, try to take PHYS 407 in the 1st semester, too.
- Transfer Students**—To transfer into the BSENV E program, you must meet the following requirements:
 - be a CEPS major or have ≥ 12 cr of graded work at UNH, Calculus I, and either chemistry or calculus-based physics with 4 year program grades of C or better or community college grades of B or better;
 - have a GPA ≥ 2.33 overall;
 Only CEE 600- and 700-level courses with a grade of C- or better may be transferred in.
- Transfer Credit**—You need grades of C or better in courses taken elsewhere to receive UNH credit. Submit a Transfer Credit Prior Approval form before taking a course elsewhere. Transferred courses fulfill UNH requirements but the grades you receive elsewhere do not transfer or affect the UNH GPA.

Notes for Ongoing Students

- Study Away*—You need both a UNH GPA ≥ 2.50 and a GPA in CEE courses also greater ≥ 2.50 .
- Writing Intensive Courses*—You must take ENGL 401, CEE 520, 620, 650, 721, and 798 plus a Technical Writing Elective (either ENGL 502 or 602).
- CEE 420 and Transfer/Advanced Students*—If you achieve junior-level status without CEE 420, or transfer from another CEPS major after taking intro course(s), petition to take a different CEPS 600-level course.
- ME 525 may be taken instead of CEE 500.
- Public Health Electives*—HMP 403, 444A, 501, 569; CEE 730* (*cannot also be counted as design elective).
- Geospatial Science Electives*—CEE 752, NR 658, NR 757, FORT 581, or ANTH 674. If courses are unavailable in Sp Soph year, this can be substituted for a discovery course and added in a future semester.
- Alternative Engineering Laboratory Electives (need approval by academic petition)*—CEE 665, CHE 709 or OE 710.
- CHEM 403/404 vs. CHEM 405*—You may take both CHEM 403 and CHEM 404 instead of CHEM 405 though this adds a course. If so, CHEM 403 is used instead of 405 for determining CEE 600-level qualification.
- Statistics Elective*—MATH 539 or MATH 644. AP Credit does not fulfill this requirement.
- WC Discovery Elective*—International students and students that study abroad may not have to take the World Cultures Discovery Course. Therefore, delay the WC elective until you're sure you need it.
- CEE 600 Level Courses*—Are restricted until students complete all double boxed courses with cumulative average ≥ 2.00 GPA and have an overall GPA of ≥ 2.00 .

Notes for Seniors

- Restrictions on the Senior CEE electives:**
 - You must take four CEE 700-level Electives totaling ≥ 12 credits, at least two of which must be design electives.
 - You must take one hydraulics and one hydrology elective.
 - Design electives cannot be double counted for other requirements, such as non-design electives, hydrology, or hydraulics electives.
- Accelerated Master's Program**—If you are a senior with a GPA ≥ 3.20 , you can be concurrently admitted to a UNH Master's program and some courses can count for both the BSENV E and the master's degree. A maximum of 8 cr can be accepted for a UNH MSCE. Up to 12 cr may be accepted for other master's degrees.
- Required Credits**—132 credits are required. If you meet the BSENV E requirements with fewer credits, you must make up the difference with additional credits. Any UNH or transfer course is acceptable to do so.

700-LEVEL CEE ELECTIVES, SEE ADVISING NOTE 16

New #	Course Title	Credits	Design	Non-Design	Hydraulics	Hydrology
CEE 719	Green Building Design	3	✓			
730	Public Health Engr Rural & Develop	3	✓	✓		
732	Solid and Hazardous Waste Design*§	4	✓	✓		
733	Public Infrastructure Asset Management	3	✓	✓		
755	Design of Press Water Trans Systems	4	✓	✓	✓	
758	Stormwater Management Designs	3	✓	✓	✓	
759	Stream Restoration	4	✓	✓	✓	
796	Bioremediation	4	✓	✓		
706	Environmental Life Cycle Assessment	3		✓		
722	Introduction to Marine Poll & Control	4		✓		
750	Ecohydrology§	3		✓		✓
751	Open Channel Flow	3		✓	✓	
753	Snow Hydrology	3		✓		✓
754	Engineering Hydrology	3		✓	✓	✓
757	Coastal Engineering	3		✓	✓	
768	Geo-Environmental Engineering	3		✓		
SAFS 632	Urban Agriculture	4		✓		
CHE 709	Air Pollution	4		✓		
OE 710	Ocean Measurements Lab	4		✓		
ESCI 705	Principles of Hydrology	4				✓
ESCI 710	Groundwater Hydrology	4				✓

* Writing intensive, § Advanced prerequisite.

ENVE PROGRAM COURSE AVAILABILITY

New #	Course Title	Fall	Spr
CEE 420	Environmental Engineering Lectures I	x	
CEE 500	Statics	x	x
CEE 502	Project Engineering	x	x
CEE 520	Environmental Pollution and Protection	x	x
CEE 620	Fund. Aspects of Envr. Engr.		x
CEE 650	Fluid Mechanics	x	
CEE 705	Sustainable Engineering	x	
CEE 720	Solid and Hazardous Waste	x	
CEE 721	Environmental Sampling	x	
CEE 723	Environmental Chemistry	x	
CEE 724	Environmental Engr. Microbiology*		x
CEE 731	Advanced Water Treatment Processes§		x

2. EnvE Course Descriptions

CEE 420 - Environmental Engineering Lectures I

Credits: 3.00

Introduces the profession, the environmental engineer as planner, designer, problem solver, and interdisciplinary team player; and the goals of the environmental engineering curriculum. Lectures by faculty and practitioners. Introduction to computer skills required for environmental engineering. Engineering ethics.

CEE 520 - Environmental Pollution and Protection: A Global Context

Credits: 4.00

Introduces environmental science and engineering and the anthropogenic causes of environmental change. Emphasizes the causes, effects, and controls of air, water, and land pollution. The political, ecological, economic, ethical, and engineering aspects of environmental pollution and control are discussed. Field trips. Writing intensive.

CEE 620 - Fundamental Aspects of Environmental Engineering

Credits: 4.00

Application of fundamental concepts of mass balance in treatment processes. Physical, chemical, and biological aspects of pollution control, and design concepts for operations and processes used in environmental engineering are discussed. Concepts of engineering ethics are presented. Students participate in a design project that involves an oral presentation and written report. Prereq: CHEM 405, CEE 650, CEE 520; or permission. Writing intensive.

CEE 626 - Field Experience

Credits: 1.00

Based on appropriate career-oriented work experience in environmental engineering. Student can get one credit for field experience. A written final report is required as well as permission of student's adviser.

CEE 627 - Internship

Credits: 2.00

Off-campus work in the environmental engineering field for on-the-job skill development. Needs to be supervised by an environmental engineering faculty member; and a proposal for the internship must be submitted and have permission of the EnvE faculty prior to the start of the internship. Prereq: permission. IA (continuous grading).

CEE 732 - Solid and Hazardous Waste Design

Credits: 4.00

Selection, design, and evaluation of unit processes employed in the treatment of solid wastes and hazardous wastes will be studied. Topics include design of materials recovery facilities, landfills, waste-to-energy facilities and hazardous waste site remedial technologies. A group term project taken from a real-world project will be required. An oral presentation by the group and preparation of a final written engineering report including alternative evaluation, permits, scheduling and economic analysis will be required from each group. Prereq: CEE 720 or permission. Writing intensive.

CEE 705 - Introduction to Sustainable Engineering

Credits: 3.00

This course begins with exploration of the precept that we live in, and must design engineering works for, a world with a finite supply of natural resources and with limited life support capacity. Tools for sustainability engineering are the focus of the course, which includes life cycle analysis and life cycle impact analysis, the metrics and mass and energy flow analyses used in the field of industrial ecology, and environmental management systems. Pre- or Coreq: CEE 520 or permission.

CEE 706 - Special Topics

Credits: 1.00 to 4.00

Advanced or specialized topics not normally covered in the regular course offerings. May be repeated to a maximum of 4 credits, but multiple topics that are not in duplicate areas may be taken to a maximum of 12 credits.

CEE 720 - Solid and Hazardous Waste Engineering

Credits: 3.00

A thorough examination of the problems that exist in hazardous and solid waste management are presented in terms of the current regulations and engineering approaches used to develop solutions. Topics include risk-based decision making, transport and fate of contaminants, and the fundamental physical, chemical, and biological concepts, which make up the basis for technological solutions to these waste management problems. Case studies are used throughout the course to highlight key concepts and provide real-world examples. Pre- or Coreq: CEE 520 or permission.

CEE 721 - Environmental Sampling and Analysis

Credits: 4.00

Theory of analytical and sampling techniques used in environmental engineering. Topics include potentiometry, spectroscopy, chromatography, automated analysis, quality control, sampling design, and collection methods. Methods discussed in lecture are demonstrated in labs. Prereq: CHEM 404 and CEE 620 or permission. Lab. Writing intensive.

CEE 722 - Introduction to Marine Pollution and Control

Credits: 4.00

Introduces the sources, effects, and control of pollutants in the marine environment. Dynamic and kinetic modeling; ocean disposal of on-shore wastes, shipboard wastes, solid wastes, dredge spoils, and radioactive wastes; and oil spills. Prereq: CEE 620 or permission.

CEE 723 - Water Chemistry

Credits: 4.00

Emphasizes the use of chemical equilibrium principles and theory, calculations, and applications of ionic equilibrium stresses. Topics include thermodynamics, kinetics, acid/base, complexation, precipitation/dissolution, and redox equilibria. Computer equilibrium modeling is presented. Prereq: CHEM 404 or CHEM 405.

CEE 724 - Environmental Engineering Microbiology

Credits: 4.00

Concepts of environmental engineering microbiology. Topics include taxonomy of species important in environmental engineering processes; microbial metabolism, interaction, and growth kinetics in environmental treatment processes; biogeochemical cycling in water; and effects of environmental parameters on environmental engineering microbial processes. Laboratories focus on microbiological methods and laboratory-scale biological treatment experiments. Prereq: CEE 520 and CEE 650 or permission. Lab. Writing intensive.

CEE 730 - Public Health Engineering for Rural and Developing Communities

Credits: 3.00

The application of environmental health engineering and sanitation principles in disease prevention and control are discussed. Special emphasis is given to areas of the world where communicable and related diseases have not yet been brought under control and to what can happen in more advanced countries when basic sanitary safeguards are relaxed. The following topics are covered: water-related diseases to include their transmission and control; safe water development, treatment, distribution and storage; and on-site wastewater treatment and disposal system.

CEE 731 - Advanced Water Treatment Processes

Credits: 4.00

The primary objective of this course is to provide the environmental engineer with an overview of physical-chemical and biological unit water treatment processes. Major emphasis is placed on the analysis and design of both conventional and advanced water treatment unit processes/operations. Prereq: CEE 620 or permission.

CEE 733 - Public Infrastructure Asset Management

Credits: 3.00

The course provides a thorough examination of the growing engineering field of Public Infrastructure Asset Management (IAM). The course enables the student to design and IAM system. It touches upon all types of public infrastructure with a particular focus on water infrastructure for the semester design project. Students build upon their engineering economics and project engineering skills and use simple IAM software along with GIS applications. Practice leaders from the industry provide guest lectures throughout the semester. A focus on triple bottom line or the societal, environmental and economic aspects of IAM are included. The format is a modified team base design learning experience providing practice in processing of technical lecture material, personal performance evaluation (frequent quizzes) and team based performance evaluation. Student groups will present their design to the class and provide a written engineering report. Pre- or Coreq: CEE 502 and CEE 620.

CEE 797 - Introduction to Project Planning and Design**Credits:** 1.00

Part one of a two part sequence. Student groups develop a project statement to address a significant environmental engineering system design. Each team prepares a project plan to be executed in CEE 798, part two of this sequence. Open only to Environmental Engineering majors. Cr/F.

CEE 798 - Project Planning and Design**Credits:** 3.00

Student groups formed in multidisciplinary design teams to prepare a design plan for a large-scale environmental engineering system including consideration of budgetary constraints, regulatory requirements, and environmental impacts. Each team prepares a final written report and gives a formal presentation. Prereq: senior environmental engineering major or permission. Writing intensive.

CEE 795 - Independent Study**Credits:** 1.00 to 4.00

A limited number of qualified seniors is permitted to pursue independent studies under EnvE faculty guidance. Seniors write terminal thesis reporting the results of their investigations. May be repeated to a maximum of 4 credits. Prereq: permission of EnvE faculty member involved.

CEE 799H - Senior Honors Thesis**Credits:** 4.00

Students in the honors program in environmental engineering complete a project under the direction of a faculty sponsor resulting in a written thesis which must be accepted by the sponsor by the end of the second semester, senior year. Four credits total during senior year; 3 of which may be used to fulfill a CEE non-design elective.

3. Required Courses

Discovery Requirements

Courses required by the EnvE major fulfill #1-6 and 12 Discovery requirements. Students select electives to satisfy the #7-11 below – one elective each.

1. One course in Writing Skills
 - a. EnvE students are required to take ENGL 401 which satisfies this requirement
2. One course in Quantitative Reasoning
 - a. EnvE students are required to take MATH 425 which satisfies this requirement
3. One Inquiry course to be completed (if possible) in the first or second year. Inquiry 444 course or inquiry attribute course should be taken as a course in #7-11 below.
4. One course in Biological Science
 - a. EnvE students are required to take CEE 724 which waives this requirement
5. One course in Physical Science
 - a. EnvE students are required to take PHYS 407 which satisfies this requirement
6. One course in Environment, Technology, and Society
 - a. EnvE students are required to take CEE 520 which satisfies this requirement
7. One course in Historical Perspectives
8. One course in World Cultures (may be also satisfied by approved study abroad programs)
9. One course in Fine and Performing Arts.
10. One course in Social Science.
11. One course in Humanities.
12. The senior capstone design requirement is satisfied by CEE 797 and 798.

These courses cannot be taken on a Pass/Fail basis. No single course may be counted in more than one Discovery group.

If you have specific questions or problems concerning your Discovery Requirements, call a degree analyst at (603) 862-1594 or (603) 862-1592, email the Registrar at Registrars.Office@unh.edu or write c/o Degree Analyst, Registrar's Office, 11 Garrison Ave., Durham, NH 03824-3511, or stop by the Graduation Department at the Registrar's Office in Stoke Hall.

Program Requirements

The EnvE major also requires students to select: one Public Health course elective, one Geospatial Science Course; one Hydrology course, and one Hydraulics course, from lists of each of these elective topics. A major must also take four CEE electives during the last three semesters, two of which are design electives, (for a minimum of 12 credits). These must be from a list of these courses approved by the EnvE faculty.

4. Program Policies and Requirements

To enter the required Junior level courses in the fall of the third year, students:

- a. must have a minimum grade-point average of 2.00 in CEE 420, Math 425, Math 426, Phys 407, CEE 500, Chem 405, CEE 520.
- b. must have achieved an overall grade point average of 2.00 or greater

To graduate with a bachelor of science in environmental engineering, a student must:

- a. earn 132 or more credits,
- b. receive credit for the EnvE program's major and elective courses, including 2 CEE design electives,
- c. satisfy the University's Discovery requirements,
- d. satisfy the University's writing intensive course requirements,
- e. earn a cumulative grade point average of 2.00 or better for all courses, and earn a cumulative grade point average of 2.00 or better for all engineering courses.

5. Writing Requirements

The EnvE curriculum includes seven writing intensive courses, thereby not only satisfying, but exceeding the University's writing requirement. The EnvE Program's writing intensive courses are: ENGL 401, ENGL 502, CEE 520, CEE 650, CEE 620, CEE 721, and CEE 798.

6. Transfer Credits

Current UNH undergraduates students wishing to transfer credits from another institution should complete a Transfer Credit/Prior Approval Form (available through the Registrar's Office) *before* taking courses elsewhere in order to establish the number of credits to be accepted and the Discovery and/or major requirement satisfied by the course.

Students complete the Transfer Credit/Prior Approval Form and supply course descriptions. Students should obtain signatures of approval in the following order: 1. Registrar's Office 2. major adviser 3. college dean, before submitting the form to the Registrar's Office.

General Information about Transfer Credits:

For course credit to transfer from another institution, the following criteria must be met:

- An official transcript has been provided by the school where the course was taken.
- The course was taken at an institution fully accredited by a regional association of schools and colleges.
- The grade earned in the class was at least a "C" or its equivalent.
- The course was not remedial or vocational in nature or taken as part of a non-credit certificate program.
- Mathematics coursework must be completed at the Pre-Calculus level, or higher, to transfer. No credit is awarded for mathematics courses which duplicate high school level Algebra or below. Credit is accepted for Finite Mathematics and Statistics courses.
- To receive credit for elementary level foreign language coursework, a student cannot have completed two or more years of study in that same language in high school
- Credit will not be awarded for any course taken the semester immediately following any academic suspension or dismissal from UNH.

AP Scores/CLEP Exams:

Students who wish to receive credit for Advanced Placement exams from high school or the College Level Examination Program must have official scores sent directly from the College Board to the UNH Transfer Coordinator, c/o the following address:

UNH Registrar's Office
11 Garrison Ave.
Durham, NH 03824-3511

Maximum Credits Accepted in Transfer:

The maximum credits accepted in transfer from all external sources:

- 96 semester hours towards a bachelor's degree.
- 48 semester hours towards an associate degree.
- 64 semester hours from associate level coursework to be applied to a bachelor's degree (this restriction does not apply to associate degree programs at UNH-Manchester or the Thompson School of Applied Science.

Grades for Transfer Credits:

Transfer credit is awarded for completed courses with a grade of "C" or better, provided those courses are comparable to courses offered at UNH.

No portion of the student's grade point average will transfer; transfer grades are not calculated into the UNH GPA.

Transfer Courses as Discovery Courses:

Only courses awarded 3 or more semester credits can be used to satisfy Discovery Program requirements.

The Discovery Program Inquiry (INQ) requirement cannot be satisfied with transfer credit from another institution and must be taken at UNH.

Transfer Courses and the Repeated Course Rule:

A course taken at another institution *may not be used* under the UNH repeated course rule. If credit is received for a UNH course, and an equivalent course is taken at another institution, no transfer credit will be allowed. Departments *may* accept equivalent course work at other institutions for grade only to satisfy departmental requirements, but no credit will be awarded.

7. Pass/Fail Regulations

1. At the beginning of the semester, obtain a Pass/Fail Form from the Registrar's Office, Stoke Hall, or download a Pass/Fail Form, have your adviser sign it, and return the form to the Registrar's Office **BEFORE THE END OF ADD PERIOD of the given semester.**
2. Pass/Fail cannot be used for Discovery Program requirements, for courses used to satisfy the University Writing Requirements, for courses required by your major or second major, for option or minor requirements, for English 401, or repeat courses. The minimum passing grade is D-.
3. Only one course (4 cr.) per semester may be taken Pass/Fail up to a maximum of 16 credits for Bachelor's degree candidates.

8. Incomplete (IC) Grades

Students unable to complete their assigned coursework due to extenuating circumstances may request an incomplete grade from the instructor. If the instructor agrees, students must follow the guidelines set by the instructor and/or those below to resolve the incomplete. Incomplete grades unresolved by the deadlines listed below will result in a grade of "F". **Students may not graduate with an IC on the transcript. All Incompletes must be resolved before a degree is awarded.**

- All students have **until mid-semester** of the subsequent term to finish their coursework (unless an earlier date is set by the instructor) and have a grade submitted. **(Grades for Fall and January Term incompletes are due at mid-semester in the Spring; Grades for Spring and Summer incompletes are due at mid-semester in the Fall).**

Students may petition for an extension of the deadline. Petitions must be approved by the student's instructor, adviser and college dean and will generally be granted only for extraordinary, non-academic reasons. Undergraduate extensions beyond the end of the semester are rarely approved.

9. Exchange Programs

BS EnvE Specific Steps if Interested in Study Abroad

1. BS EnvE students will be introduced to UNH study abroad opportunities during admitted student day(s), WildCAT days and/or in the CEE 420 class.
2. BS EnvE students interested in study abroad at UNH should gain more information from the following two UNH program links: <https://www.unh.edu/global/start> and <https://globale3.studioabroad.com/>. Students should also reach out to Catherine D'Auteuil, (Catherine.DAuteuil@unh.edu) at UNH Global for advising.
3. The EnvE study abroad advisor (currently Prof. Malley) at their discretion will also provide information to all students interested in study abroad including key dates, requirements, schedules of information sessions, etc.
4. EnvE students should consider the following with respect to study abroad opportunities:
 - a. Plan to study abroad early in their time at UNH – spring of sophomore year would be the ideal time since most students will have greater flexibility in matching to a desired location and program if they are taking courses that count as Discovery (note that Discovery program committee approval is needed for a particular course taken abroad to count as a UNH discovery requirement), or Math-Statistics, public health electives, etc. It is a good policy to plan on taking 4 courses while abroad and having a back-up course for as many of those four as possible before arriving at the location and program of choice. Studying abroad during spring of sophomore year requires advanced planning beginning spring freshman year.
 - b. It is unavoidable that there will be case-by-case circumstance (transfer students, students deciding or becoming eligible (GPA) later to go abroad, particular location and program chosen, etc.). These students may find themselves in a challenging situation to find course matches that keep them on track for graduation. The EnvE faculty would like to recommend the following:
 - i. These students should be encouraged to examine the Global E3 options since matching courses in other engineering programs is inherently easier.
 - ii. It is likely these students have completed most of the courses mentioned in 4a that are easy to match so those students are encouraged to try and match course that are relatively standard (especially in Global E3 programs) such as fluid mechanics and/or hydraulics, basic or intro environmental engineering, hydraulics electives, hydrology electives, some schools have also had good matches for a water chemistry, environmental microbiology, etc.
 - iii. It is preferred that CEE Design electives not be filled through study abroad due to difficulties with documentation for ABET.
 - iv. CEE Engineering Science electives may be filled through study abroad if they are from an engineering department and can be tied to the student's career path.

v. Special cases do arise such as a class in the sciences that is being taught by an engineering professor and has a syllabus that clearly demonstrates engineering science content. In these circumstances the student can petition the EnvE faculty for course approval.

5. As with all things related to undergraduate curriculum at UNH, ultimately it is the student's responsibility to ensure that they complete the requirements for graduation with the ABET accredited BS EnvE degree and the students have the freedom to petition for academic variances at either the department level of the university level.

10. Professional Registration

The Fundamentals of Engineering or FE exam is given in October and April every year. This is a day-long examination covering science, chemistry, electrical engineering and computer science at the level you will have experienced these topics in your undergraduate courses. The FE exam is the first step toward registration as a professional engineer. After a specified number of years of professional practice you are then qualified to take the Professional Engineering exam, which is much narrower in scope, but at level of greater depth in the area of professional practice of your choice. That is the final examination in the process of obtaining professional registration. Depending upon the nature of the work that you do, professional registration may be a requirement. The best time to take the FE exam is when you are a senior as your familiarity with the various topics is at its best. Applications, exam dates, and deadlines are available via the FE website at <https://www.oplc.nh.gov/engineers/index.htm>.

11. Honors in Major – Environmental Engineering

1. Students eligible for Honors in Major are required to maintain an overall 3.50 grade-point average and a 3.50 grade-point average in major coursework.
2. Students must successfully complete 12 credits of honors coursework in at least two courses (Junior level) and one senior level course offered by the Environmental Engineering Program. Honors courses will involve increased work assignments, (i.e., laboratory experiments/analysis, research, design projects, literature review, term papers, lectures of comprehensive examination). Students registering for honors designated coursework must follow the University Honors Program Course Designation Guidelines <http://www.unh.edu/honors-program/designating-course-honors>
3. Students must successfully complete 799H Senior Honors thesis (4 cr. total during senior year; 3 credits of which may be used to fulfill a CEE non-design elective). An individual project must be completed under faculty guidance resulting in a written thesis which is to be submitted to the Department and the Honors Program by the end of the second semester of senior year.

Contact: Environmental Engineering Students: Kevin Gardner – 603-862-4334

12. Five Year BS/M.Eng. Option

Students can earn an M.Eng. in Civil Engineering in one year of academic work beyond obtaining their BS ENE degree. [Note: UNH does not offer an MS or PhD program in Environmental Engineering.] The M.Eng. program requires 30 credits of coursework. Thus, a student can complete and receive both the BS and the MS in five years at UNH. Additionally, students are required to complete a project or a final examination. Students in the MEng program are not eligible for financial support as a TA or RA.

For more information about this program, see your academic advisor and the following link:

<http://ceps.unh.edu/CEE/civil-engineering-meng>

13. Accelerated Masters Program

At UNH, students have the additional benefit of being able to apply for Early Admission with the UNH Graduate School (<http://www.gradschool.unh.edu/index.php>). Students who do so can “double count” two courses for up to eight graduate credits. (These two courses count for both the BS and the Masters Degree.) Early admission is restricted to UNH seniors only, typically in place for the spring semester of their senior undergraduate year, and requires a 3.50 cumulative GPA.

For more information about this program, see your academic advisor.

14. Leave of Absence Policy

New Leave of Absence Policy

The Faculty Senate has approved a new Leave of Absence (LOA) policy effective Fall 2017.

Faculty Senate, working in conjunction with the Dean of Students, amended the Leave of Absence policy to simplify the process for students wishing to take a break from University studies for a variety of personal reasons.

Please note a few specifics:

- Students no longer have to apply for a Leave of Absence.
- Any student in good standing (academic and/or conduct) may take a leave of absence for up to six semesters.
- Students submit a Leave of Absence form to the Office of the Registrar.
- Students on a LOA are not considered matriculated and are subject to the same loan repayment rules as withdrawn students.
- All academic rules pertaining to withdrawn students also apply to LOA students.
- No coursework taken at other institutions during a LOA will be accepted as transfer credit.

Like the current withdrawal process, a student should contact the Office of the Registrar to obtain a Leave of Absence form.

Reinstatement:

- Students submit an “Undergraduate Return from Leave of Absence” form with the Office of the Registrar to be reinstated.
- If the student wishes to return to a different major than declared at the point of LOA, the student would file a readmission application with the Office of Admission.
- Due dates for the “Undergraduate Return from Leave of Absence” form are the same as for the Readmission Application process (June 1 for fall term; November 1 for spring term).

Students do still have the option to withdrawal entirely from the University if the intent is to transfer to another institution or if the intent is to not return.

The new Leave of Absence rules and procedures are posted at the Office of the Registrar Website at <http://www.unh.edu/registrar/registration-courses/withdrawal-leave-of-absence.html>.

Please contact Elizabeth Smith, Associate Registrar, at Elizabeth.smith@unh.edu with questions.

C. EnvE Faculty

1. Faculty Contact Information

<u>NAME</u>	<u>OFFICE</u>	<u>TELEPHONE</u>	<u>EMAIL</u>
Dr. Thomas Ballestero*	Gregg Hall 238	603-862-1405	tom.ballestero@unh.edu
Dr. Robin Collins	Gregg Hall 348	603-862-1407	robin.collins@unh.edu
Dr. Kevin Gardner	Gregg Hall 336	603-862-4334	kevin.gardner@unh.edu
Dr. James Houle †	Gregg Hall 244	603-767-7091	james.houle@unh.edu
Dr. Jennifer Jacobs*	Morse Hall 453	603-862-0635	jennifer.jacobs@unh.edu
Dr. Nancy Kinner	Gregg Hall 216	603-862-1422	nancy.kinner@unh.edu
Dr. James Malley	Gregg Hall 344	603-862-1449	jim.malley@unh.edu
Dr. Weiwei Mo	Gregg Hall 334	603-862-2808	weiwei.mo@unh.edu
Dr. Paula Mouser	Gregg Hall 236	603-862-3275	paula.mouser@unh.edu
Dr. Alison Watts †	Gregg Hall 248	603-862-0585	alison.watts@unh.edu

*Drs. Ballestero and Jacobs are CEE faculty members, part of whose curriculum affiliation is with the BSEnvE degree program.

†Research faculty member.

2. Faculty Bios

Dr. Thomas P. Ballestero, an Associate Professor of Civil/Environmental Engineering, is a hydrologist and water resources engineer. He received his B.S. (1975) and M.S. (1977) in Civil Engineering from Penn State, and a Ph.D. (1981) in Hydrology and Water Resources Engineering from Colorado State. At Penn State, in-between M.S. and Ph.D. degrees, Dr. Ballestero taught water resources courses and professional short courses on computer simulation. From 1979 – 1983, he was the manager of the water resources engineering division of Simons, Li and Associates, Inc. In this capacity, Dr. Ballestero was project manager for projects dealing with water resources development (ground water and surface water supplies), hydropower feasibility analyses, hydrologic analysis and simulation, evaluation of contaminant migration, water rights, and design and evaluation of water monitoring networks. Also, Dr. Ballestero was involved with proposals, corporate marketing, expert witness testimony and corporate management. In 1983, Dr. Ballestero entered his present appointment at UNH where he teaches eleven different courses in hydrology and water resources. His research interests are broadly in the field of water resources computer simulation and field measurement of parameters in surface and ground water systems. Dr. Ballestero has strong research and consulting lines in stream restoration and stormwater management. In 2002 he started the UNH Stormwater Center of which he is the Director and Principal Investigator. Since 2005, he has held a joint position with the US Fish & Wildlife Service performing all aspects of stream restoration. He chaired the Civil Engineering Department from 1993 – 1999, and he was director of the New Hampshire Water Resources Research Center from 1986 to 1999. Dr. Ballestero holds professional licensures of: PE, PH, PG, and CGWP.



Dr. M. Robin Collins, P.E., is a Professor of Civil/Environmental Engineering. He completed a B.S.C.E with distinction (1970) and an M.S. in Sanitary Engineering (1972) from Virginia Polytechnic Institute and State University, and a Ph.D. from the University of Arizona (1985). Dr. Collins is a registered professional civil and environmental engineer and is currently the Director of the Water Treatment Technology Assistance Center. Dr. Collins has expertise in water treatment design and operations and on-site wastewater disposal systems. He has extensive professional experience working with municipalities as an engineering consultant, a district engineer for state regulatory (KS and WY) agencies, and as a Sanitary Engineer for the U.S. Army. He has successfully conducted research in cooperation with numerous water utilities and funding agencies by characterizing natural organic matter and disinfection by-product precursor and microbial removals from selected water treatment processes including slow sand filtration, diatomaceous earth filtration, membrane filtration, riverbank filtration and conventional chemical clarification treatment. He has worked with numerous public water suppliers and consulting engineers nationwide in evaluating and piloting several filtration options, especially slow sand filtration. More recently, he has researched post-treatment aeration techniques in water distribution storage tanks and pipelines, and developed drip-chlorination systems that can adjust to varying flows without electricity. His research efforts have been honored by the AWWA by serving as the major advisor to the 1990, 1993, 1998, and 2005 recipients of the Academic Achievement Award for Best Thesis. Dr. Collins teaches courses on water chemistry, environmental pollution and control, public health engineering and water treatment processes, and is the senior faculty advisor to the UNH Chapter of Engineers Without Borders.



Dr. Kevin H. Gardner is a registered professional environmental engineer and a Professor of Civil and Environmental Engineering. He also serves as the Director of Strategic Initiatives in the Office of the Senior Vice Provost for Research. Dr. Gardner received his B.S. in Civil Engineering from Union College in 1989 and his M.S. and Ph.D. from Clarkson University in Environmental Engineering in 1992 and 1996, respectively. Dr. Gardner teaches courses related to Sustainable Engineering, contaminant fate and transport and environmental chemistry. Dr. Gardner's research focus includes many topics related to sustainability, sustainability science, life cycle assessment, behavior of contaminants in aquatic environments, and remediation of contaminated sediments.



Dr. James Houle is the Program Director for the Stormwater Center. His responsibilities include directing and managing the Stormwater Center's growing body of research projects. Areas of expertise include diffusion of innovative stormwater management solutions, the design and implementation of innovative stormwater control measures including green infrastructure (GI), and low impact development (LID) strategies, planning and implementation, operation and maintenance, and water resource monitoring. Dr. Houle holds a Ph.D in Natural Resources and Environmental Science and has over fifteen years of experience with water quality related issues in New England and is a certified professional in storm water quality (CPSWQ) and a certified professional in erosion and sediment control (CPESC).



Dr. Jennifer M. Jacobs received her Sc.B from Brown University in 1987, her M.S. from Tufts University in 1993, and her Ph.D. from Cornell University in 1997. Dr. Jacobs has been a faculty member at UNH since 2003. Dr. Jacobs was a faculty member at the University of Florida from 1997 to 2003. She was also a consultant for the Boston Systems Group and Eastern Research Group from 1987 to 1993. Dr. Jacobs is a water resources engineer and Professor of Civil/Environmental Engineering. She is advancing interdisciplinary research at the margins of environmental engineering, social sciences and physical sciences. A key focus is advancing technologies which can improve the quality of life and environment. As a full-time member of the faculty, Dr. Jacobs teaches undergraduate and graduate courses in fluid mechanics, water resources, and surface water hydrology. Dr. Jacobs conducts experimental research in snow hydrology, watershed hydrology, land-surface and water energy dynamics with an emphasis on the application of emerging technologies to current research needs. Currently, Dr. Jacobs' students are investigating mechanisms of snowmelt driven flooding. Increasingly, their work is informed by climate and land use changes that are forcing existing hydrologic analysis frameworks to be reconsidered. Dr. Jacobs is the PI of the NSF RCN SEES ICNet project.



Dr. Nancy E. Kinner is a University Professor, an environmental engineering microbiologist and Professor of Civil/Environmental Engineering. Dr. Kinner has conducted research on the role of protists in contaminant degradation, and petroleum and chlorinated solvent bioremediation. Dr. Kinner teaches courses on the fundamentals of environmental engineering, and marine pollution and control. She has also studied bioremediation of contaminated bedrock aquifers. Dr. Kinner is the UNH Co-Director of the UNH Coastal Response Research Center funded by NOAA's Office of Response and Restoration and Director of the UNH Center for Spills and Environmental Hazards. The Centers fund research on oil spill response, restoration, and recovery and has been involved in R&D issues related to the drilling in the Arctic and the Deepwater Horizon spill in the Gulf of Mexico.



Dr. James P. Malley, Jr., is a Professor of Civil/Environmental Engineering. He has a B.S.E.S. (1980) from Rutgers University; and a B.S.C.E. (1988), M.S. (1984), and Ph.D. (1988) in Environmental Engineering from the University of Massachusetts. Dr. Malley teaches classes in solid and hazardous waste engineering and design. Dr. Malley is committed to involving students at all levels (from rising first year students to graduate students in his research and scholarship activities). If you are interested in undergraduate research opportunities, ask about the MalleyCATS.



Dr. Malley has been active in the environmental engineering field for over 30 years and has served as a principal advisor on 75 drinking water projects in 9 countries involving bench, pilot, demonstration and full-scale testing that range in size from 0.14 to 2,600 million gallons per day. Dr. Malley is committed to providing safe drinking water to people in developing nations around the world through groups such as Water for People and Engineers without Borders. He has conducted millions of dollars in research and has published over 100 papers and technical reports including being a principal author of the 2006 UV Disinfection Guidance Manual for USEPA which is the industry gold standard for UV validation. Dr. Malley served as Chairman of the Board of Trustees for the Water Quality and Technology Division of AWWA (2007-2010) and is currently Vice-Chairman of the AWWA Technical and Education Council. Dr. Malley received the 2013 UNH Award for Outstanding Public Service. Years of experience and hundreds of professional contacts allow Dr. Malley to help students become part of the engineering profession and obtain internship and job offers.

Dr. Weiwei Mo is an assistant professor in the Department of Civil and Environmental Engineering. She got her BS degree from Shanghai Jiao Tong University in China (2008), and her MS (2011) and PhD (2012) degrees from University of South Florida. Before coming to UNH, she was a post-doctoral associate at Yale University. Her research interests include life cycle assessment, systems analysis of interactions between resource, infrastructure, and human, integrated resource recovery (energy, nutrients, water) in WWTPs, and water-energy nexus. She is currently a leader of several National Science Foundation funded projects, working on optimization of decentralized urban water and energy supply, crowdsourced strategy applied to household water sampling and testing, and human-nature interactions surrounding decision-making. She teaches undergraduate and graduate courses in environmental pollution and control, environmental sampling and analysis, life cycle assessment, and system dynamics modeling.



Dr. Paula J. Mouser is an Associate Professor of Civil/Environmental Engineering and licensed professional engineer. As an environmental engineering microbiologist, her research investigates bioprocesses that influence the fate of contaminants in aquatic and subsurface systems, including rivers, sediments, aquifers, and deep fractured shales. She received her B.S. In Environmental Engineering from Utah State University in 1998 and completed her M.S. and P.hD. from the University of Vermont in Civil and Environmental Engineering in 2003 and 2006, respectively. She was a post-doctoral research associate in the Department of Microbiology at the University of Massachusetts in 2006-2007, and has over five years of professional experience working with municipalities and as an engineering consultant. Prior to joining UNH in 2017, Dr. Mouser was a faculty member at the Ohio State University from 2011-2017. Dr. Mouser teaches undergraduate and graduate courses on environmental microbiology, bioprocesses, and bioremediation.



Dr. Alison W. Watts received a B.A. from Mt. Holyoke College (1984), an M.S. in Geology from Arizona State University (1992), and a Ph.D. in Civil Engineering from the University of New Hampshire (2006). She joined the Civil Engineering Department in 2009 as a Research Assistant Professor of Civil Engineering. Dr. Watts works with the UNH Stormwater Center, and her research includes a study of polycyclic aromatic hydrocarbon (PAH) transport in storm water runoff, research on the movement and transformation of PAHs, focusing on transport in wetland plants, and wetland systems; nutrient removal mechanisms; statistical analysis of hydrologic data; ecological assessment of stormwater wetlands, and the use of stormwater wetlands to treat deicing runoff from airports. Dr. Watts has experience in groundwater studies, and wetlands mapping, as well as course work in hydrology, wetlands ecology, environmental microbiology, and geostatistics. She is involved in natural resource and wetlands conservation in her local community, and is chair of the Newfields Conservation Commission. Dr. Watts is a NH Professional Geologist, and has over ten years of experience as a consultant in contaminant investigations, site assessment and remediation.



Environmental Engineering Office

The Environmental Engineering Office is located in Gregg Hall Room 222 and is open from 7:30 a.m. to 12:00 noon, and from 12:30 p.m. to 4:00 p.m. Monday through Friday. The EnvE Program Support Assistant, Maddy Wasiewski; and the EnvE Administrative Assistant, Madison Abeels provide and coordinate a broad range of services for the faculty and students of the Program. Students are encouraged to contact them during office hours about any concerns, questions, or help they may need at 603-862-2206.

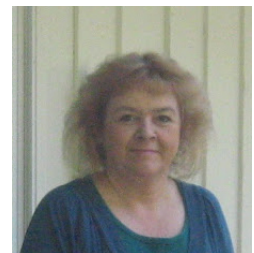

Preamble

Engineering is an important and learned profession. As members of this profession, engineers are expected to exhibit the highest standards of honesty and integrity. Engineering has a direct and vital impact on the quality of life for all people. Accordingly, the services provided by engineers require honesty, impartiality, fairness, and equity, and must be dedicated to the protection of the public health, safety, and welfare. Engineers must perform under a standard of professional behavior that requires adherence to the highest principles of ethical conduct.

I. Fundamental Canons

Engineers, in the fulfillment of their professional duties, shall:

1. Hold paramount the safety, health, and welfare of the public.
2. Perform services only in areas of their competence.
3. Issue public statements only in an objective and truthful manner.
4. Act for each employer or client as faithful agents or trustees.
5. Avoid deceptive acts.
6. Conduct themselves honorably, responsibly, ethically, and lawfully so as to enhance the honor, reputation, and usefulness of the profession.

II. Rules of Practice

1. Engineers shall hold paramount the safety, health, and welfare of the public.

- a. If engineers' judgment is overruled under circumstances that endanger life or property, they shall notify their employer or client and such other authority as may be appropriate.
- b. Engineers shall approve only those engineering documents that are in conformity with applicable standards.
- c. Engineers shall not reveal facts, data, or information without the prior consent of the client or employer except as authorized or required by law or this Code.
- d. Engineers shall not permit the use of their name or associate in business ventures with any person or firm that they believe is engaged in fraudulent or dishonest enterprises.
- e. Engineers shall not aid or abet the unlawful practice of engineering by a person or firm.
- f. Engineers having knowledge of any alleged violation of this Code shall report thereon to appropriate professional bodies and, when relevant, also to public authorities, and cooperate with the proper authorities in furnishing such information or assistance as may be required.

2. Engineers shall perform services only in the areas of their competence.

- a. Engineers shall undertake assignments only when

qualified by education or experience in the specific technical fields involved.

- b. Engineers shall not affix their signatures to any plans or documents dealing with subject matter in which they lack competence, nor to any plan or document not prepared under their direction and control.
- c. Engineers may accept assignments and assume responsibility for coordination of an entire project and sign and seal the engineering documents for the entire project, provided that each technical segment is signed and sealed only by the qualified engineers who prepared the segment.

3. Engineers shall issue public statements only in an objective and truthful manner.

- a. Engineers shall be objective and truthful in professional reports, statements, or testimony. They shall include all relevant and pertinent information in such reports, statements, or testimony, which should bear the date indicating when it was current.
- b. Engineers may express publicly technical opinions that are founded upon knowledge of the facts and competence in the subject matter.
- c. Engineers shall issue no statements, criticisms, or arguments on technical matters that are inspired or paid for by interested parties, unless they have prefaced their comments by explicitly identifying the interested parties on whose behalf they are speaking, and by revealing the existence of any interest the engineers may have in the matters.

4. Engineers shall act for each employer or client as faithful agents or trustees.

- a. Engineers shall disclose all known or potential conflicts of interest that could influence or appear to influence their judgment or the quality of their services.
- b. Engineers shall not accept compensation, financial or otherwise, from more than one party for services on the same project, or for services pertaining to the same project, unless the circumstances are fully disclosed and agreed to by all interested parties.
- c. Engineers shall not solicit or accept financial or other valuable consideration, directly or indirectly, from outside agents in connection with the work for which they are responsible.
- d. Engineers in public service as members, advisors, or employees of a governmental or quasi-governmental body or department shall not participate in decisions with respect to services solicited or provided by them or their organizations in private or public engineering practice.
- e. Engineers shall not solicit or accept a contract from a governmental body on which a principal or officer of their organization serves as a member.

5. Engineers shall avoid deceptive acts.

- a. Engineers shall not falsify their qualifications or permit misrepresentation of their or their associates' qualifications. They shall not misrepresent or exaggerate their responsibility in or for the subject matter of prior assignments. Brochures or other presentations incident to the solicitation of employment shall not misrepresent pertinent facts concerning employers, employees, associates, joint ventures, or past accomplishments.
- b. Engineers shall not offer, give, solicit, or receive, either directly or indirectly, any contribution to influence the award of a contract by public authority, or which may be reasonably construed by the public as having the effect or intent of influencing the awarding of a contract. They shall not offer any gift or other valuable consideration in order to secure work. They shall not pay a commission, percentage, or brokerage fee in order to secure work, except to a bona fide employee or bona fide established commercial or marketing agencies retained by them.

III. Professional Obligations

1. Engineers shall be guided in all their relations by the highest standards of honesty and integrity.

- a. Engineers shall acknowledge their errors and shall not distort or alter the facts.
- b. Engineers shall advise their clients or employers when they believe a project will not be successful.
- c. Engineers shall not accept outside employment to the detriment of their regular work or interest. Before accepting any outside engineering employment, they will notify their employers.
- d. Engineers shall not attempt to attract an engineer from another employer by false or misleading pretenses.
- e. Engineers shall not promote their own interest at the expense of the dignity and integrity of the profession.

2. Engineers shall at all times strive to serve the public interest.

- a. Engineers are encouraged to participate in civic affairs; career guidance for youths; and work for the advancement of the safety, health, and well-being of their community.
- b. Engineers shall not complete, sign, or seal plans and/or specifications that are not in conformity with applicable engineering standards. If the client or employer insists on such unprofessional conduct, they shall notify the proper authorities and withdraw from further service on the project.
- c. Engineers are encouraged to extend public knowledge and appreciation of engineering and its achievements.
- d. Engineers are encouraged to adhere to the principles of sustainable development⁸ in order to protect the environment for future generations.

- e. Engineers shall continue their professional development throughout their careers and should keep current in their specialty fields by engaging in professional practice, participating in continuing education courses, reading in the technical literature, and attending professional meetings and seminars.
- 3. Engineers shall avoid all conduct or practice that deceives the public.**
 - a. Engineers shall avoid the use of statements containing a material misrepresentation of fact or omitting a material fact.
 - b. Consistent with the foregoing, engineers may advertise for recruitment of personnel.
 - c. Consistent with the foregoing, engineers may prepare articles for the lay or technical press; but such articles shall not imply credit to the author for work performed by others.
 - 4. Engineers shall not disclose, without consent, confidential information concerning the business affairs or technical processes of any present or former client or employer, or public body on which they serve.**
 - a. Engineers shall not, without the consent of all interested parties, promote or arrange for new employment or practice in connection with a specific project for which the engineer has gained particular and specialized knowledge.
 - b. Engineers shall not, without the consent of all interested parties, participate in or represent an adversary interest in connection with a specific project or proceeding in which the engineer has gained particular specialized knowledge on behalf of a former client or employer.
 - 5. Engineers shall not be influenced in their professional duties by conflicting interests.**
 - a. Engineers shall not accept financial or other considerations, including, free engineering designs, from material or equipment suppliers for specifying their product.
 - b. Engineers shall not accept commissions or allowances, directly or indirectly, from contractors or other parties dealing with clients or employers of the engineer in connection with work for which the engineer is responsible.
 - 6. Engineers shall not attempt to obtain employment or advancement or professional engagements by untruthfully criticizing other engineers, or by other improper or questionable methods.**
 - a. Engineers shall not request, propose, or accept a commission on a contingent basis under circumstances in which their judgment may be compromised.
 - b. Engineers in salaried positions shall accept part-time engineering work only to the extent consistent with policies of the employer and in accordance with ethical considerations.
- c. Engineers shall not, without consent, use equipment, supplies, laboratory, or office facilities of an employer to carry on outside private practice.
- 7. Engineers shall not attempt to injure, maliciously or falsely, directly or indirectly, the professional reputation, prospects, practice, or employment of other engineers. Engineers who believe others are guilty of unethical or illegal practice shall present such information to the proper authority for action.**
 - a. Engineers in private practice shall not review the work of another engineer for the same client, except with the knowledge of such engineer, or unless the connection of such engineer with the work has been terminated.
 - b. Engineers in governmental, industrial, or educational employ are entitled to review and evaluate the work of other engineers when so required by their employment duties.
 - c. Engineers in sales or industrial employ are entitled to make engineering comparisons of represented products with products of other suppliers.
 - 8. Engineers shall accept personal responsibility for their professional activities, provided, however, that engineers may seek indemnification for services arising out of their practice for other than gross negligence, where the engineer's interests cannot otherwise be protected.**
 - a. Engineers shall conform with state registration laws in the practice of engineering.
 - b. Engineers shall not use association with a nonengineer, a corporation, or partnership as a "cloak" for unethical acts.
 - 9. Engineers shall give credit for engineering work to those to whom credit is due, and will recognize the proprietary interests of others.**
 - a. Engineers shall, whenever possible, name the person or persons who may be individually responsible for designs, inventions, writings, or other accomplishments.
 - b. Engineers using designs supplied by a client recognize that the designs remain the property of the client and may not be duplicated by the engineer for others without express permission.
 - c. Engineers, before undertaking work for others in connection with which the engineer may make improvements, plans, designs, inventions, or other records that may justify copyrights or patents, should enter into a positive agreement regarding ownership.
 - d. Engineers' designs, data, records, and notes relating exclusively to an employer's work are the employer's property. The employer should indemnify the engineer for use of the information for any purpose other than the original purpose.

Footnote 1: "Sustainable development" is the challenge of meeting human needs for natural resources, industrial products, energy, food, transportation, shelter, and effective waste management while conserving and protecting environmental quality and the natural resource base essential for future development.

"By order of the United States District Court for the District of Columbia, former Section II(c) of the NSPE Code of Ethics prohibiting competitive bidding, and all policy statements, opinions, rulings or other guidelines interpreting its scope, have been rescinded as unlawfully interfering with the legal right of engineers, protected under the antitrust laws, to provide price information to the prospective clients; accordingly, nothing contained in the NSPE Code of Ethics, policy statements, opinions, rulings or other guidelines prohibits the submission of price quotations or competitive bids for engineering services at any time or in any amount."

Statement by NSPE Executive Committee

In order to correct misunderstandings which have been indicated in some instances since the issuance of the Supreme Court decision and the entry of the Final Judgment, it is noted that in its decision of April 25, 1978, the Supreme Court of the United States declared: "The Sherman Act does not require competitive bidding."

It is further noted that as made clear in the Supreme Court decision:

1. Engineers and firms may individually refuse to bid for engineering services.
2. Clients are not required to seek bids for engineering services.
3. Federal, state, and local laws governing procedures to procure engineering services are not affected, and remain in full force and effect.
4. State societies and local chapters are free to actively and aggressively seek legislation for professional selection and negotiation procedures by public agencies.
5. State registration board rules of professional conduct, including rules prohibiting competitive bidding for engineering services, are not affected and remain in full force and effect. State registration boards with authority to adopt rules of professional conduct may adopt rules governing procedures to obtain engineering services.
6. As noted by the Supreme Court, "nothing in the judgment prevents NSPE and its members from attempting to influence governmental action . . ."

Note: In regard to the question of application of the Code to corporations vis-a-vis real persons, business form or type should not negate nor influence conformance of individuals to the Code. The Code deals with professional services, which services must be performed by real persons. Real persons in turn establish and implement policies within business structures. The Code is clearly written to apply to the Engineer, and it is incumbent on members of NSPE to endeavor to live up to its provisions. This applies to all pertinent sections of the Code.

UNH Academic Honesty Policy

09 Academic Honesty (From Section 9 of the UNH Rights and Responsibilities Handbook)

Honesty is a core value at the University of New Hampshire. The members of its academic community both require and expect one another to conduct themselves with integrity. This means that each member will adhere to the principles and rules of the University and pursue academic work in a straightforward and truthful manner, free from deception or fraud.

Any attempts to deviate from these principles will be construed as acts of academic dishonesty and will be dealt with according to the rules of due process outlined below.

The value of honesty and the expectation of conduct that goes with it are intended to reinforce a learning environment where students and faculty can pursue independent work without unnecessary restraints. At the same time, the University recognizes its responsibility to encourage and inculcate values and standards of conduct that will guide its students throughout their careers.

The academic honesty policy provides standards of conduct for individuals only. Policies relating to recognized student organizations are described elsewhere. Such organizations, however, are expected to conform to the values and standards that govern their members as individuals within the UNH community. It is expected that students attending the University will conduct themselves in accordance with the rules and regulations of the University. Students must acknowledge the University's right to take disciplinary action, including suspension or dismissal, for failure to comply with the expectations delineated by this policy.

This policy establishes the expectations of the University of New Hampshire for academic honesty and defines situations that constitute academic misconduct. Finally, it presents the due process that follows should misconduct occur.

While it is impossible to list all cases that might arise, the following are provided as examples of academic dishonesty.

09.1 Written Classroom Examinations

Presenting the work of other students as one's own, or assisting another student to do so, in a written classroom examination is considered to be cheating. Cheating may also occur when a student violates the conditions governing the examination.

Examples include, but are not limited to the following:

1. using oral, written, visual, or other form of communication intended to give or receive improper assistance;
2. looking at or copying another's work;
3. using unauthorized materials (texts, notes, etc.);
4. having a surrogate take an exam;
5. altering your work after an exam has been returned and before resubmitting it;
6. obtaining and/or using an upcoming exam ahead of time.

09.2 Out-of-Class Work

Collaboration or aid on out-of-class work, when prohibited by the instructor, is considered to be cheating. Such unauthorized activity includes, but is not limited to the following:

1. receiving outside help on take home exams;
2. consulting with others about homework, laboratory reports, etc.;
3. copying another's homework, laboratory reports, etc., and submitting them as your own.

09.3 Plagiarism

The unattributed use of the ideas, evidence, or words of another person, or the conveying of the false impression that the arguments and writing in a paper are the student's own. Plagiarism includes, but is not limited to the following:

1. the acquisition by purchase or otherwise of a part or the whole of a piece of work which is represented as the student's own;
2. the representation of the ideas, data, or writing of another person as the student's own work, even though some wording, methods of citation, or arrangement of evidence, ideas, or arguments have been altered;
3. concealment of the true sources of information, ideas, or argument in any piece of work.

09.4 Misrepresentation

The deliberate falsification of information substituted in place of the truth is misrepresentation and includes but is not limited to the following:

1. having another person represent or stand in for oneself in circumstances where the student's attendance and/or performance is required;
2. leaving a class, laboratory, etc. without permission but after attendance has been taken;
3. presenting false academic credentials;
4. having another person author one's written work;
5. submitting work originally submitted for one course to satisfy the requirements of another course, without prior consent of the current instructor (it is assumed that the current instructor expects the work to be original);
6. forging or using another's signature;
7. altering or destroying academic records and documents;
8. presenting false data, experimental results, or physical results.

09.5 Academic Policy

Violations of academic policy that are considered as academic dishonesty include but are not limited to the following:

1. removing materials from the library with out proper authority;
2. infringing on the rights of other students to fair and equal access to academic resources;
3. duplicating course materials expressly forbidden by the instructor;
4. ignoring or willfully violating class or laboratory instructions or policies.

09.6 Computers

Violations of computer codes of ethics distributed at the University will be considered academic dishonesty.

09.7 Procedures for Dealing with Academic Misconduct

A student shall be informed of any accusation of academic misconduct. The procedure for handling such cases shall be as follows:

1. Individual cases will be handled initially by the instructor of the course concerned, as required by the instructor's professional responsibility to assess the performance of his or her students. The instructor will notify the student of the alleged infraction and what course of action and penalty the instructor believes is appropriate. The student must be allowed an opportunity to rebut the allegation. The initial notification and conference are to be conducted informally. The chair of the department offering the course should be apprised on any actions taken. The penalty imposed by the instructor may not exceed failure in the course, in which case the student should be informed in writing that a failing grade is being assigned for academic misconduct and that further appropriate action may be taken by the student's college dean. Cases shall be reported to the student's college dean at the discretion of the instructor and department chair, except when a failing grade in the course is assigned for academic misconduct, in which case the student's college dean shall be notified of that fact.
2. Cases involving academic misconduct by students not enrolled in the course in question will be referred to the student's college dean, in which case the procedures detailed in section (1) above will be followed.
3. The student's college dean, when informed of an academic misconduct case as in (1) or (2) may take appropriate further action including suspension or dismissal; however, such action shall not take place before the student has been advised by the dean or his/her representative in writing in a timely fashion (normally before the semester succeeding the precipitating infraction) of the charges, and not before the student has been given an opportunity to explain or reply to the charges.
4. Any student penalized under those procedures may appeal the decision. In any appeal, the student involved has the right to the presence of an advisor of the student's choice drawn from the University community.
 - A. to appeal an instructor's decision, a written request for appeal must be sent to the student's college dean in a timely fashion, normally within 30 days, unless the student presents evidence of circumstances preventing such a timely response. Normally within two weeks the dean will schedule a meeting with the student to afford the student an opportunity to explain or reply to the charges. A dean's appellate decision can be appealed further to the Academic Standards and Advising Committee, which will consider the appeal only on the basis of procedural irregularities. Any new data or evidence that becomes available will return the case to the student's college dean.
 - B. In cases where the student's college dean is the primary respondent, or in cases where the student's college dean imposes a significant further penalty beyond

that imposed by the course instructor, appeals of the dean's decision must be made in writing and in a timely fashion(as defined in 4 A.) directly to the Academic Standards and Advising Committee. The chair of that committee will respond normally within two weeks by scheduling a hearing to afford the student an opportunity to explain or reply to the charges. In such a case that committee will hear substantive as well as procedural complaints. In any such case the representative of the student's college dean to the Academic Standards and Advising Committee will be excused from the committee's deliberations.

As approved by the Faculty Senate February 25, 1991

09.8 Reporting

It shall be the responsibility of the student's college dean to report to the Academic Standards and Advising Committee all actions and all appeals from students resulting from cheating cases.

Note: Cases involving graduate students are referred to the Associate Dean of the Graduate School. Appeals of the Associate Dean's decision can be made to the Dean of the Graduate School who may, at his/her discretion, refer the case to the Graduate Council for review. Students who are dismissed by the Associate Dean and wish to appeal that decision should follow the procedures for graduate students dismissed for academic reasons.

3. EnvE Student Code of Ethics

EnvE Program
Student Code of Ethics
University of New Hampshire, Durham, NH

I understand that the work of environmental engineers impacts society in a variety of social, economic, and environmental ways and that professional negligence can result in the loss of property, widespread illness, damage to the environment, and the loss of human life. I understand that environmental engineering practice, therefore, requires high ethical standards that hold paramount the safety health, and welfare of the public. By signing below, I pledge the following:

- I commit myself to be honest and to honor and respect the rights of others.
- I will not plagiarize, cheat on exams, assist others in doing so, or tolerate such behavior in others.
- I have received and read the National Society of Professional Engineers (NSPE) Code of Ethics for Engineers. I understand what is written therein, and pledge to uphold this Code of Ethics both as a student and as a practicing engineer.
- I have received and read Section 9 on Academic Honesty of the document *Student Rights, Rules, and Responsibilities*, of the University of New Hampshire and will pursue my academic work at UNH in a straightforward and truthful manner, free from deception or fraud. Furthermore, I understand the procedures for dealing with academic misconduct and understand the consequences including the possibility of outright dismissal from UNH.

Printed Name

Signature

Date Signed

E. Facilities and Resources

1. Gregg Hall

The EnvE program is housed in Gregg Hall. Gregg Hall is a four-story, 55,000 square foot building that has a multidisciplinary science and engineering research focus on environmental technology development and includes classrooms, project work space, a computer room, laboratories, instrumentation rooms, constant temperature rooms, high bay areas, faculty, staff and graduate student offices, conference/meeting rooms, and an audio/visual multimedia room for presentations and videoconferencing. EnvE students have access to many amenities in Gregg Hall, including student lockers, project work space rooms, building-wide wireless networking, kitchens, 8-station computer room, color printers and plotters, and multimedia classrooms, like Gregg 320. One of the most significant attributes of the physical environment is the close relationship enjoyed by graduate and undergraduate EnvE students, faculty and staff. Undergraduates have unfettered access to faculty while working on projects or in the laboratories, but also have support and benefit from interaction with the graduate students and EnvE research staff members. Many EnvE courses are taught in Gregg 110, which can seat up to 45 students. Gregg 320 is used for teaching when intensive multimedia capabilities are required and is used for EWRI meetings and presentations by students, faculty and seminar speakers.

Office and computing facilities in Gregg Hall are excellent. EnvE students have access to a computer room with eight PC workstations as well as high-speed wireless throughout the building. The wireless network system ensures access in laboratories, classrooms, project work space rooms, meeting rooms, and other areas where EnvE outcomes are being achieved. Two color laser printers, two black-and-white laser printers, a 48" color plotter, two scanners, and a copier/scanner/FAX machine are all available to EnvE students in Gregg Hall. In addition, the multimedia room (Gregg 320) offers a digital presentation system, projector with touch system, and blu-ray/dvd player. EnvE students make use of the multimedia room by making presentations to classes and constituents, and participating in videoconferences.

Students in the EnvE program also use Kingsbury Hall. Kingsbury also has infrastructure conducive to student research, with student lab and high-bay space for projects, as well as appropriate heating, air conditioning and ventilation throughout. All classrooms have LCD projectors, including two state-of-the-art lecture halls in Kingsbury to accommodate larger groups. Kingsbury has high-speed wireless internet access in all classrooms and labs. The EnvE teaching laboratories are located in Kingsbury Hall. These are a specialized design to accommodate the physiochemical treatment, environmental sampling and analysis and environmental engineering microbiology laboratory courses. Gregg Hall and Kingsbury Hall are a short distance from each other, allowing students easy access to faculty, staff, and graduate students, as well as the engineering library, numerous computer clusters with a wide array of software. Gregg Hall allows close proximity to common interdisciplinary partners such as the Hubbard Genome Center, and the Chase Ocean Engineering lab. Laboratories at UNH are routinely inspected by UNH Office of Environmental Health and Safety to ensure a safe working environment. Kingsbury Hall, open 24 hours per day, contains the popular student coffee shop Albert's, allowing students to take breaks and obtain refreshments without the need to travel long distances. The program is also within walking distance from the Town of Durham Water Treatment Facility, and a short drive from the wastewater treatment facility, both of which are used extensively for tours, sampling sources, and have been previously used as an experiment site by students.

2. Kingsbury Hall

Civil and Environmental Engineering Department Office

The Civil and Environmental Engineering Department Office is located in Kingsbury Hall Room W183 and is open from 8:00 a.m. to 12:00 noon, and from 1:00 p.m. to 4:30 p.m., Monday through Friday. The department Administrative Assistants, Michelle Mancini and Kristen Parenteau, provide and coordinate a broad range of services for the faculty and students of the Department. Students are encouraged to contact them during office hours about any concerns, questions, or help they may need at 603-862-1428. The department has a branch office in Gregg Hall room 222 where EnvE student records are kept. It is staffed by Maddy Wasiewski the EnvE Administrative Assistant and a work study student. The offices hours are 7:30am to 12:00pm and 12:30pm to 4:00pm Monday through Friday. Students may come to the office or call 603-862-2206 for assistance.

Engineering, Mathematics & Computer Science Library

The Engineering, Mathematics & Computer Science library is a branch of the main UNH library. It serves the College of Engineering and Physical Sciences, UNH departments, research units, and those in the community with interests and needs within the areas of computer science, mathematics and statistics, and chemical, civil and environmental, mechanical, and electrical and computer engineering. The library includes a collection of 26,000 books, 890 current periodical subscriptions, and thousands of bound journal volumes. The library is located in Kingsbury Hall room S236. For more information please call 603-862-1740 or visit <http://www.library.unh.edu/branches/engmathcs.html>.

3. Student Mailboxes

You should check your mailbox on a regular basis for notices, announcements, and returned assignments. Student mail folders are maintained in Gregg Hall Room 209. Students may also have a University mailbox on the second floor of the Memorial Union Building. More information about the university mailboxes can be found at <https://www.unh.edu/mub/gss>

4. Textbooks

Students are advised not to buy any textbooks until enrolled in courses. Textbooks cannot be returned for full price if they have been used or students have written in them. Textbooks can be purchased in a variety of ways, either locally or online. Local bookstores where textbooks can be purchased are: the Durham Book Exchange (36 Main Street) and the UNH Bookstore (2nd Floor of the Memorial Union Building). Textbook information for courses can be found at: <https://unh.bncollege.com/webapp/wcs/stores/servlet/TBWizardView?catalogId=10001&langId=-1&storeId=29555>

5. Tutoring

Students who are experiencing academic difficulties can obtain help through a number of tutoring programs.

- a) For math courses, the Math Department runs a tutoring program at the Math Center (MaC Center). Here they offer help with calculus courses and students are strongly encouraged to seek help with their homework and to ask questions. The MaC Center is located at the bottom of Christensen Hall and opens the beginning of the second week of classes. Help is available on Monday and Wednesday from 1-9 p.m., on Tuesday and Thursday from 9-5 p.m., on Friday from 1-5 p.m., and on some Sundays 2-5 p.m. For more information, contact the MaC Center at 862-3576 or visit their website: http://www.unh.edu/math/math_mac.html
- b) The Tau Beta Pi honor society also runs a tutoring program which covers many first year/sophomore courses. For more information please contact Professor Mike Carter, faculty advisor, at mike.carter@unh.edu.
- c) Tutoring is also available through the Center for Academic Resources (CFAR). For more information please call them at 862-3698 or visit their website: <https://www.unh.edu/cfar>
- d) Teaching assistants (TA's) are available for many CEE courses. A list of TA's and their contact information is posted in the syllabus and in the MyCourse pages for each course.

6. Academic Advising

Each student is assigned an academic advisor who is a faculty member in the EnvE Program of the Department of Civil and Environmental Engineering. Students should consult their advisor for registration, and any other academic advice or signatures they may need. Check with the Maddy Wasiewski if you do not know who your academic advisor is.

7. Student Organizations

On campus:

American Society of Civil Engineers (ASCE): ASCE provides access to quality information, works to improve the image of Civil Engineers, and provides career resources. Participate locally in the steel bridge and/or concrete canoe competition.

ASCE Student Officers:

President	Jacob Veronneau	jv1041@wildcats.unh.edu
Treasurer	Ryan Daley	rwd1010@wildcats.unh.edu
Professional Development	Edward Mahoney	efm1005@wildcats.unh.edu
Vice President	Nicholas Buonanno	nmb1014@wildcats.unh.edu
Fundraiser	Logan Stevens	lhs1008@wildcats.unh.edu
Social Media Chair	Adam Wielebinski	arw1036@wildcats.unh.edu
Room Scheduler	Liam Cullinane	lmc1035@wildcats.unh.edu
Underclass Outreach Chair	Wei He	wh1000@wildcats.unh.edu
Faculty Advisor	Kyle Kwiatkowski	kyle.kwiatkowski@unh.edu

UNH-Environmental and Water Resources Institute (EWRI) is a student lead organization established to expose students to a variety of topics and events which promote environmental awareness and sustainability at UNH and beyond! EWRI provides students with opportunities to give back to the community and network with peers, faculty and professionals which could lead to internships and jobs down the road.

UNH-EWRI Student Officers

President	Chloe Carter	cmc1060@wildcats.unh.edu
Vice-President	Emma Thibodeau	ect1004@wildcats.unh.edu
Secretary	Nicola Elardo	nme1003@wildcats.unh.edu
Treasurer	Matthew Carter	mc1187@wildcats.unh.edu
Marketing/ Fundraising	Sawyer Hall	sbh1007@wildcats.unh.edu
Marketing/Fundraising	Jacqueline Dumont	jed1047@wildcats.unh.edu
Marketing/Fundraising	Deirdre Rafferty	dmr1037@wildcats.unh.edu
Peer Networking	Cassidy Yates	cry1004@wildcats.unh.edu
Community Outreach	Nicola Elardo	nme1003@wildcats.unh.edu
Professional Development	Tori Sweet	tls1033@wildcats.unh.edu
Professional Development	Christopher Keohane	cpk1017@wildcats.unh.edu

Jim Malley

Faculty Advisor

jim.malley@unh.edu
603-862-1449

Engineers Without Borders (EWB): The mission of Engineers Without Borders-UNH is to encourage, support, and implement environmentally, socially, and economically sustainable technical projects for local and international communities, while developing globally responsible and knowledgeable students. <https://unhewb.org/>. Students Without Borders (SWB) shares the same goals and student body as EWB, but works on separate projects that do not require reporting to a national organization. <http://unhswb.org/>

President	Michelle Thibault	met1019@wildcats.unh.edu
Secretary	Clara Miller	crm1043@wildcats.unh.edu
Treasurer	Spencer McKinnon	swm1006@wildcats.unh.edu
Project Lead	Kevin Johnson	khj1000@wildcats.unh.edu
Project Lead	Steven Rizzo	scr1020@wildcats.unh.edu
Project Lead	Giovanni Guglielmi	gg1041@wildcats.unh.edu
Project Lead	Lauren Courtemanche	lac1024@wildcats.unh.edu
Project Lead	Devan Sack	dps1024@wildcats.unh.edu
Grants Chair	Sara Moriarty	sem1042@wildcats.unh.edu
Fundraising Chair	Megan Cramton	mc1436@wildcats.unh.edu
Vice President	Sarah Zecha	sjz1001@wildcats.unh.edu
Recruitment Chair	William Conley	wec1008@wildcats.unh.edu

Advisors:

Faculty Advisor
Technical Advisor

Dr. Robin Collins
Dr. Tom Ballestero

robin.collins@unh.edu
tom.ballestero@unh.edu

Society of Women Engineers (SWE): The Society of Women Engineers, founded in 1950, is a non-profit educational and service organization. SWE is the driving force that establishes engineering as a highly desirable career aspiration for women. SWE empowers women to succeed and advance in those aspirations and be recognized for their life-changing contributions and achievements as engineers and leaders. <https://wildcatlink.unh.edu/organization/swe>.

President	Meghan Otis	mco1011@wildcats.unh.edu
Vice President	Olivia Dube	omd1000@wildcats.unh.edu
Secretary	Anna Lampman	agl1008@wildcats.unh.edu
Treasurer	Nicola Elardo	nme1003@wildcats.unh.edu

Faculty Advisor:

May-Win Thein may-win.thein@unh.edu
603-862-1158

Off-campus National Organizations with student memberships:

AWWA (American Water Works Association): International nonprofit scientific and educational society dedicated to the improvement of drinking water quality and supply. <http://www.awwa.org/>

WEF (Water Environment Federation): Trade association focused upon preserving and enhancing the global water environment. <http://www.wef.org/Home>

AEESP (Association for Environmental Engineering and Science Professors): The Association of Environmental Engineering and Science Professors (AEESP) is made up of professors in academic programs throughout the world who provide education in the sciences and technologies of environmental protection. <https://www.aeesp.org/>

Environmental Engineering Student Forum (EESF): AEESP has organized an Environmental Engineering and Science student forum to serve as an organizational umbrella for environmental students. This forum will allow students to be exposed to a variety of fields and professional organizations of environmental engineering and science. <http://www.aeesp.org/membership>

National Ground Water Association (NGWA): The mission of NGWA is to enhance the skills and credibility of all ground water professionals, develop and exchange industry knowledge and promote the ground water industry and understanding of ground water resources. <https://www.ngwa.org/members/join-ngwa/Students>

Solid Waste Association of North America (SWANA): For over 40 years, the Solid Waste Association of North America has been the leading professional association in the solid waste field. Our association serves over 7,200 members throughout North America, and thousands more with conferences, certifications, publications, and technical training courses.

Air and Waste Management Association (AWMA): The Air & Waste Management Association (A&WMA) is a nonprofit, nonpartisan professional organization that provides training, information, and networking opportunities to thousands of environmental professionals in 65 countries.

<http://www.awma.org/>

8. MyCourses by Canvas

Most UNH courses use “MyCourses” by Canvas as their online instructional tool. CEE students are automatically subscribed to departmental MyCourses sites where a variety of information can be found, including directories, announcements, curriculum worksheets, job/internship postings, and scholarship postings. All student are also given access to Webcat, where all of their academic information is available.

9. Important UNH Resources and Services

Student Accessibility Services:

Student Accessibility Services (SAS) provides services to students with documented disabilities to ensure that all University activities and programs are accessible. The office also promotes the development of student self-reliance and the personal independence necessary to succeed in a university climate.

<http://www.unh.edu/studentaccessibility/>

Center for Academic Resources:

The mission of the Center for Academic Resources is to assist undergraduate students in achieving their academic potential and in maximizing their educational experience at UNH. They teach active learning skills and skills that promote academic effectiveness and critical thinking. They also provide information and referrals to local resources.

<https://www.unh.edu/cfar>

Connors Writing Center:

The Robert J. Connors Writing Center is committed to supporting the writing of everyone in the University of New Hampshire community. The writing center is a comfortable space to talk with our writing assistants about your writing. If you've got a quick grammar or citation question, you can send them an instant message with AIM. Their screen name is: unhwritingcenter

<http://www.unh.edu/writing/>

Undergraduate Research Opportunities Program (UROP):

Whether through taking a research-intensive course, working in one of the University's many centers or institutes, or teaming up with a favorite professor to pursue a mutual academic interest, the opportunities to become involved in research abound for students of all majors. If you've never had exposure to the research process, how do you get started? Through the Undergraduate Research Opportunities Program (UROP). They have the resources to make research an integral part of your undergraduate experience, during the academic year or the summer, in the United States and around the world.

<http://www.unh.edu/undergrad-research/>

International Research Opportunities Program (IROP):

Surf the website and then begin your research with a visit to the IROP coordinator, who can answer your questions about our program and provide the application materials you will need to pursue an IROP grant.

<http://unh.edu/undergrad-research/international-research-opportunities-program-irop>

Summer Undergraduate Research Fellowships (SURF):

SURF grants are awarded to students who wish to conduct research over the summer at various locations in the U.S. or overseas; the grants may also support research that contributes to a senior project or thesis.

<http://unh.edu/undergrad-research/summer-undergraduate-research-fellowships-surf>

Counseling Center:

The Center helps students fully benefit from their time at UNH through individual counseling, group counseling, psychological testing, psychiatry, campus outreach, and consultation to faculty and staff.

<http://www.unh.edu/pacs/>

Environmental Engineering (EnvE) Program Website:

Visit the environmental engineering program website for more information about EnvE programs, people, and current news.

<https://ceps.unh.edu/cee/environmental-engineering-bs>

Registrar's Office:

The Registrar's Office is responsible for registration and academic record keeping for all students at the University. The office maintains students' permanent records, and produces student schedules, data audits, and grade reports. Graduation staff track students' progress toward completion of Discovery and University requirements and provide degree audits to students. The office provides official and unofficial transcripts and enrollment verifications for current students and alumni. Visit their website for:

<http://www.unh.edu/registrar/>

Time and room schedules (class schedules by semester)

Academic calendar and deadlines

Final exam schedules

Graduation information

Registration information

Discovery information

Registrar's Office forms

Undergraduate Course Catalog:

Includes course descriptions for all UNH courses.

<https://catalog.unh.edu/undergraduate/>

UNH Information Technology:

UNH Information Technology delivers network and communications infrastructure, as well as provides IT services that support students, faculty & staff with learning and research.

<https://www.unh.edu/it/>

UNH Health Services:

UNH Health Services is an integrated health and wellness service that operates from a holistic perspective. In support of the University's academic mission, they provide medical care, wellness education, and health promotion.

<http://www.unh.edu/health-services/welcome>

University Advising and Career Services:

Advisors are available for advising and career appointments

www.unh.edu/uacc

SHARPP (Sexual Harassment & Rape Prevention Program):

The mission of the Sexual Harassment & Rape Prevention Program is to eliminate sexual and intimate partner violence. SHARPP's mission is accomplished in two parts: by providing free and confidential advocacy and direct services to all survivors and their allies; and by offering culturally competent awareness and prevention programs to the University of New Hampshire community.

www.unh.edu/sharpp

10. Important UNH Phone Numbers and Web Addresses

Center for Academic Resources	862-3698	https://www.unh.edu/cfar
Center for Undergraduate Research	862-4323	www.unh.edu/undergrad-research
CEPS Academic Affairs Office	862-1783	www.ceps.unh.edu
Civil and Environmental Engineering Department	862-1428	www.unh.edu/civil-engineering
UNH Information Technology	862-4242	http://www.unh.edu/it/
Connor's Writing Center	862-3273	www.unh.edu/writing/
Counseling Center	862-2090	http://www.unh.edu/pacs/
Disability Services for Students	862-2607	http://www.unh.edu/studentaccessibility/
Environmental Engineering Office	862-2206	https://ceps.unh.edu/cee/environmental-engineering-bs
Health Services	862-1530	www.unh.edu/health-services
Honors Program	862-3928	www.unh.edu/honors-program
International Research Opportunities Program (IROP)	862-4323	http://unh.edu/undergrad-research/international-research-opportunities-program-irop
Libraries Main (Diamond) CEPS (Kingsbury)	862-1535 862-1196	www.library.unh.edu
MUB (Memorial Union Bldg) Information Center	862-2600	www.unhmub.com/
Registrar's Office	862-1500	www.unh.edu/registrar
SHARPP (Sexual Harassment & Rape Prevention Program)	862-3494	www.unh.edu/sharpp
Student Organization Services	862-4764	https://www.unh.edu/mub/involvement-leadership
Student Senate	862-1494	www.unh.edu/student-senate
Telecom	862-1030	https://telecom.unh.edu/apps/summit
University Advising and Career Services	862-2064	www.unh.edu/uacc
Undergraduate Research Opportunities Program (UROP)	862-4323	http://www.unh.edu/undergrad-research/
University Police/Security/Escort Services	862-1427	www.unh.edu/upd
Emergency Dial 911		

F. Environmental Engineering Research Groups

1. Overview

The EnvE faculty conduct research particularly in eight areas, each an important issue to New Hampshire and New England communities and private sector firms as well as to the nation and the world. Research is undertaken on other issues when expertise is sought by New Hampshire communities or firms, but it is in these eight areas that the Group has a critical mass of talent, demonstrated significant expertise, and concentrated its program development efforts.

- **Environmental Engineering Microbiology Research**
- **Center for Spills and Environmental Hazards**
- **Coastal Response Research Center**
- **Contaminant Fate, Transport, and Remediation**
- **Drinking Water Treatment Technologies**
- **Electrotechnologies Research**
- **Recycled Materials and Waste Utilization**
- **Stormwater and Wastewater Treatment**
- **Stream and Wetland Restoration**
- **Infrastructure and Climate Network**
- **Center for Sustainable Infrastructure**
- **Bioremediation Research**

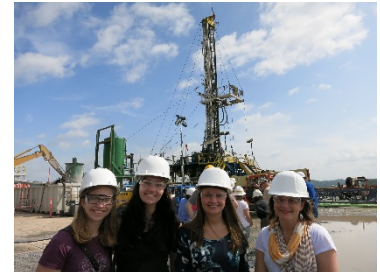

Environmental Engineering Microbiology Research

The Environmental Engineering Microbiology Research Group investigates how microorganisms break down contaminants in wastewater and natural systems. The center utilizes a suite of analytical chemistry and 'omics-based tools (genomics) to understand microbial physiology and cultivates bacteria from unique subsurface environments, such as deep fractured shale wells. Applications of research include stimulating microbial populations to more efficiently remove contaminants through a better fundamental understanding of their metabolisms, or identifying physiological short circuits that result in the incomplete breakdown of contaminants in the environment. The center is led by Dr. Paula Mouser (603.862.3275, paula.mouser@unh.edu).



Center for Spills and Environmental Hazards

The Center for Spills in the Environment (CSE), created in 2004 in conjunction with its affiliate Coastal Response Research Center (CRRC) focuses on issues related to hydrocarbon spills. The Center is known for its independence and excellence in the areas of environmental and marine science and engineering as they relate to spills. CSE has conducted numerous workshops bringing together researchers, practitioners and NGOs of diverse backgrounds to address issues in spill response, restoration and recovery. The Center is directed by Dr. Nancy Kinner (603.862.1422, nancy.kinner@unh.edu).



Coastal Response Research Center

The [Coastal Response Research Center](#) focuses on developing new approaches to spill response and restoration in marine and estuarine environments through research and synthesis of information. A partnership between the National Oceanic and Atmospheric Administration (NOAA) and the University of New Hampshire, the Center stimulates innovation in spill preparedness, responses, assessment, and implementation of optimum spill recovery strategies. The Center is directed by Dr. Nancy Kinner (603.862.1422, nancy.kinner@unh.edu).



Contaminant Fate, Transport, and Remediation

The UNH Contaminated Sediment Center was developed in response to regional and national needs to characterize, treat, and manage contaminated dredged materials from ports, harbors, and waterways. The Center is directed by Dr. Kevin Gardner (603.862.4554, kevin.gardner@unh.edu).

Drinking Water Treatment Technologies

The New England Water Treatment Technology Assistance Center is a hub for water treatment. Group efforts in advanced water treatment technology focus on the need of small communities and firms for reliable, affordable systems for drinking water. Concern for safer drinking water, as well as new Federal requirements, are forcing communities to upgrade to more advanced treatment methods. Technologies that are currently available will result in massive cost increases, so new technologies are urgently needed. The Center is funded by the U.S. EPA. Dr. Robin Collins (603.862.1407; robin.collins@unh.edu) directs the Center.



Electrotechnologies Research

The **Electrotechnologies Research Program** examines the applications of ultraviolet light, pulsed ultraviolet light, electric fields, pulsed electric fields, electron beams, sonic waves, and other emerging technologies for treatment of hazardous wastes and air pollution and for the disinfection of drinking water and wastewater. Dr. James Malley (603.862.1449, jim.malley@unh.edu) heads the program.

Infrastructure & Climate Network (ICNet)

Dr. Jacobs is the PI of the ICNet project (603.862.0635, jennifer.jacobs@unh.edu).

The Infrastructure & Climate Network (ICNet) is a network of over 60 academics, students, and practitioners who are dedicated to accelerating climate science and engineering research in the Northeastern United States. The ICNet focuses on climate change and sea level rise impacts and adaptation for sustainable bridges, roads, and transportation networks. The ICNet was established in October 2012 with support from the National Science Foundation.



Stormwater Treatment and Management

Although many of the stormwater management devices are based on sound theory, there is no requirement that they undergo independent, third-party scientific testing. The [UNH Stormwater Center](#) is designed to study stormwater-related water quality and quantity issues. One unique feature is the field facility to evaluate and verify the performance of stormwater management devices and technologies. Fifteen different management systems are currently undergoing side-by-side comparison testing under strictly controlled conditions. The Center is funded through NOAA and is directed by Dr. Tom Ballesterio (603.862.1405, tom.ballesterio@unh.edu).

Stream and Wetland Restoration Institute

The Stream and Wetland Restoration Institute is directed by Dr. Tom Ballesterio (603.862.1405, tom.ballesterio@unh.edu).

Stream and wetland restoration endeavors to return impaired systems to their near natural state. Often this is constrained by the many aspects of human activities, and that is why complete restoration may not always be possible. Restoration activities cover a very large spectrum, including but not limited to: changes to hydrology (for example instream flow, or connection of flood plain wetlands), dam removal, improved stream crossings, geomorphic stream designs, riparian buffers, improved floodplain conveyance, creating hyporheic fluxes, and improving fish and wildlife connectivity. In order to ultimately get to the process of restoration, understanding fundamental ecosystem functions and characteristics is imperative. This understanding is biologic, hydrologic, geologic (sediment and geomorphology), hydraulic, and sociologic. The better the understanding of these system components, the more likely the success of the restoration activities.



The UNH Center for Infrastructure Resilience to Climate (UCIRC)

Dr. Jo Daniel is the director of CIRC (603.862.3277, jo.daniel@unh.edu).

The UNH Center for Infrastructure Resilience to Climate (UCIRC) is dedicated to accelerating and advancing the development of new methods and approaches to planning, design, and operation and maintenance of climate and weather resilient transportation and building infrastructure systems. UCIRC is also working to develop and implement effective public policy solutions concerning these pressing issues. The Center brings together UNH faculty and students for interdisciplinary, collaborative research to tackle these multi-dimensional issues. UCIRC builds on the leading-edge work conducted by the Infrastructure and Climate Network (ICNet). UCIRC works hand-in-hand with New Hampshire's private sector, providing engineering companies with the resources to be more competitive and to bring innovative ideas to market.



2. Staff Directory

<u>Name</u>		<u>Email</u>	<u>Center</u>
Damon Burt	603-862-1412	damon.burt@unh.edu	New England Water Treatment Technology Assistance Center
Fabrizio Colosimo	603-862-0564	Fabrizio.Colosimo@unh.edu	Dept. of Civil and Environmental Engineering
David Kaiser	603-862-2719	david.kaiser@noaa.gov	Coastal Response Research Center
Jenna Luek	603-862-0819	jenna.luek@unh.edu	Dept. of Civil and Environmental Engineering
Kathy Mandsager	603-862-1545	kathy.mandsager@unh.edu	Coastal Response Research Center
Kellen Sawyer	603-862-1412	Kellen.sawyer@unh.edu	New England Water Treatment Technology Assistance Center
Madeleine Wasiewski	603-862-2206	maddy.wasiewski@unh.edu	Dept. of Civil and Environmental Engineering
Peter Dwyer	603-862-1106	pdwyer@cisunix.unh.edu	New England Water Treatment Technology Assistance Center
Scott Greenwood	603-862-0538	scott.greenwood@unh.edu	Recycled Materials Resource Center
2 nd Floor Grad Office	603-862-1172		
3 rd Floor Grad Office	603-862-1197		